

Non Domestic EPC Conventions for England & Wales Issue 8

These conventions have been agreed by the Non-Domestic Energy Performance Certificate (NDEPC) Conventions Group and approved by DLUHC. These Conventions are part of the on-going work to standardise the assessment process to ensure uniformity of approach in a way that will assist Accreditation Schemes and Non-Domestic Energy Assessors (NDEAs) and at the same time provide assurance to consumers that a consistent approach is being taken to carrying out energy assessments. The Conventions Group was set up with the agreement of DLUHC.

A copy of these conventions, which apply to assessments in England and Wales only, have been sent to NDEAs by their Accreditation Scheme(s). The Conventions must be applied by all accredited NDEAs and by those NDEAs currently in training. The scope of these conventions is limited to clarifying how the assessment methodology is to be applied when a non-domestic EPC is produced. They do not by doing so in any way affect whether or not the Energy Performance of Buildings (England and Wales) Regulations 2012 require one to be produced.

To enable Accreditation Schemes, Energy Assessors and training providers to manage the implementation process please note that new conventions must be applied on the date shown in the document. These conventions will be included as part of future quality assurance checks of the assessments undertaken, and the EPCs produced, by NDEAs thereafter. New and amended conventions for v8.0 are highlighted by a light blue background. The conventions are designed to improve the quality and accuracy of NDEPCs. The conventions will, therefore, supersede any previous assessment process including the iSBEM manual. The conventions outlined in this document should be used unless they conflict with the requirements of Part L of the Building Regulations in which case Part L always takes precedence. With this in mind, further conventions are being discussed and developed by the Conventions Group and these will be released in due course.

If NDEAs have any questions about the conventions, they must feed them back to their Accreditation Scheme so the issue they have raised, where appropriate, can be discussed at a future meeting of the Conventions Group. The conventions must be applied as issued, even if NDEAs believe there may be a convention that requires further clarification, until the Conventions Group has the opportunity to discuss the issue in more detail. Any subsequent changes to the conventions will be circulated to all NDEAs.

Note that these conventions also apply, under separate direction to Approved Organisations by the Scottish Government, to assessments in Scotland. In this respect, any reference to Accreditation Schemes or relevant regulations may be taken as the equivalent term applicable in Scotland.

Non Domestic EPC Conventions for England & Wales Issue 8

Ref	Issue	Convention	Implementation date
1. Fundamentals			
1.01	Apportionment of On-site Renewable (OSR) Electricity Generation	<p>To be included in any EPC calculation the on-site renewable (OSR) electricity generation must be connected to the electrical installation on the consumer side of the primary supply meter serving the building (or building part) being assessed. Provided this condition is met:</p> <ol style="list-style-type: none"> OSR electricity generation is allocated to the primary supply meter the OSR is attached to. If it is clear that the meter serves more than one building (or building part) then the OSR should be apportioned to all of the buildings (or building parts) to which the meter is attached on an area weighted basis. Where it cannot be determined that the OSR supply is attached to a meter serving the building (or building part) being assessed then no OSR electricity generation should be allocated to that building (or the building part). 	<p>1 September 2014</p> <p>Amended 1 May 2017</p>
2. General Information			
2.01	Assessment Level	Refer to assessment level decision flowchart and notes – (Issue 1 1 st June 2010) amended in issue 2.	17 January 2011
2.02	Use of Defaults	<p>The energy assessor shall only use the default values within the Software Tool in the absence of any conventions identified within this document or more specific information on the building. Where a default value is selected the assessor must provide evidence detailing why the default value has been selected to enable their Accreditation Scheme to verify appropriate use of default values during Quality Assurance processes.</p> <p>Use of default values should be avoided where possible.</p>	1 June 2010
2.03	Air Permeability	<p>The SBEM default value of 25 m³/hr m⁻² for all existing buildings shall be amended as follows:</p> <ul style="list-style-type: none"> Less than 10 m³/hr m⁻² – only with an accredited air pressure test result 10 m³/hr m⁻² – buildings > 500 m² built to 2002 Building Regulations (or later) 15 m³/hr m⁻² – buildings ≤ 500 m² built to 2002 Building Regulations (or later) 15 m³/hr m⁻² – Buildings built to 1995 Building Regulations 25 m³/hr m⁻² – buildings built to Building Regulations pre 1995 (pre 1994 in Scotland) 35 m³/hr m⁻² – to be considered where buildings are pre 1995 regulations (pre 1994 in Scotland) and where suitable evidence of high permeability exists, e.g. single skin metal clad structure within Planning Use Class B2 – B8 with large roller shutter doors and poor constructional details etc. 	<p>1 June 2010</p> <p>Amended 30 November 2012</p> <p>Amended 1 May 2017</p> <p>Amended 1 July</p>

Non Domestic EPC Conventions for England & Wales Issue 8

		In the case of a building part designed or modified to be used separately the air permeability is determined by the floor area of the building part, except where multiple parts are primarily accessed via a common entrance; in which case, it is determined by the total floor area of all the parts sharing the common entrance.	2018
2.04	SBEM Weather Locations	For EPCs in England select the weather location closest to the subject address using the Excel lookup file – based on the Postcode Area (the initial 1 or 2 letters in the first part of the postcode). For EPCs in Wales, software assigns a single weather location (Cardiff). For EPCs in Northern Ireland the software should automatically default to 'Belfast'. For EPCs in Scotland, software assigns a single weather location (Glasgow). See 'SBEM Weather Locations 10.05'	1 February 2012 Amended 1 May 2017 Amended 1 July 2018
2.05	Planning Use Class	The Energy Assessor is not responsible for establishing the official authorised Planning Use Class of a particular building. However, if Assessors are provided with the authorised Planning Use Class from a suitable source, then this should be entered as the 'Building Type' under the building 'General Details' data entry form. Otherwise, the Building Type will be based on the Assessor's visual assessment of the building on the day of inspection. In both cases, the Assessor is at liberty to alter the Building Type on a zone by zone basis as necessary, in order to model the activity types as seen. The Assessor should as a matter of course, record and be able to provide evidence for the selection of the main building type chosen and any subsequent changes made to the building type at zone level.	1 February 2012
2.06	As Built Data	Documentary evidence provided by the client's design team upon which the Energy assessor is relying to produce an EPC shall be the 'As Built' documentation only. Suitable evidence will include, but not be confined to:- <ul style="list-style-type: none"> • Drawings which clearly indicate they are the 'As Built drawings' OR drawings accompanied by a statement from the designer(s) stating the drawing numbers and issue and the drawings are 'As Built' • As Built specification documentation accompanied by a statement from the designer(s) confirming that the specification is 'As Built' • Commissioning documentation including air permeability test certificates, ductwork leakage test certificates, air handling units leakage test certificates • Power factor correction documentation • Statement from designer(s) of As Built U-values or As Built calculations supplied by design team • Documented and dated specific answers to 'As Built' questions raised by the Energy Assessor to the 	1 September 2014

Non Domestic EPC Conventions for England & Wales Issue 8

		<p>design team to confirm details for the production of the EPC e.g. Lighting design, specific fan powers, BMS details, district heating carbon emissions</p> <ul style="list-style-type: none"> Letter from the architect/engineer stating that the 'As Built' building has not changed from the "As Designed" specifications. <p>It is not acceptable to use Design documentation only for the production of an EPC.</p>	
2.07	Acceptable Documentary Evidence	<p>Potential Types of Acceptable Documentary Evidence (not exhaustive)</p> <ul style="list-style-type: none"> Building Control sign-off sheets Technical design information Manufacturer's technical data sheets Calculations from an accredited individual Installation record / Safety records / checks Service / maintenance record / schedule Purchase Order / Delivery Note Operation / maintenance manual /User guide / instructions Letters/Emails from the architect/engineer/manufacturer's technical support <p>General rule: in all cases where documentary evidence is utilised, there must be a demonstrable link between visual observations taken on site and the additional documentary evidence used.</p> <p>A common example is the identification of boilers where a visual inspection might be inconclusive on its own but the identification of a Model No. from the site inspection can be directly read across to a manufacturer's data sheet in order to identify the boiler efficiency. If that direct link cannot be made then the additional documents cease to be acceptable documentary evidence.</p> <p>This principle must be applied in all cases where documentary evidence is used, i.e. there must be a direct identifiable link between the data observed and recorded on site and the additional information obtained from the documents via a part no., model no. etc.</p> <p>If the Assessor is confident with the source, consistency and the quality of the information provided including letters and emails and it agrees with the visual observations on site then this should be adequate for the process, otherwise the information should not be used.</p>	1 September 2014
2.08	Use of Address Line 1 to Describe Site Buildings and Building	<p>Due to the complexity of sub dividing large buildings into functional areas requiring an EPC, it is difficult to be completely prescriptive about how to format the information that constitutes sub address information. However, in order to minimise the creation of duplicate sub addresses, Accreditation Schemes and Energy Assessors should adhere to the following guidelines.</p>	1 May 2017

Non Domestic EPC Conventions for England & Wales Issue 8

Sub Parts	<p>Note that, for Scotland, separate guidance is published on these topics to reflect the operation of the Scottish EPC register and addressing practice.</p> <p>Site Building</p> <ul style="list-style-type: none">○ Site Building should only be used where the base address / UPRN refers to multiple buildings. Examples of this would be hospitals or campuses where there is a single postal address, but multiple buildings.○ There are no further rules for formatting this field. The assessor should identify the building using the most appropriate description, perhaps agreed between the assessor and the person commissioning the EPC, e.g. “Operating Theatre” or “Great Hall”. <p>NB: Please note that under this process a refinement to an existing address/UPRN is being requested (rather than a new address/UPRN).</p> <p>Building Part</p> <ul style="list-style-type: none">○ Building Part should be used to identify a sub division within a building.○ The Energy Assessor should generate the Building Part using the following building part hierarchy: <p style="padding-left: 40px;">Floor Details</p> <p style="padding-left: 80px;">↳ Room or suite details</p> <p>Note that this is normally returned from the PAF (Post Office Address File) details.</p> <p>For example, “Floor 16, Portland House”</p> <p>Changes to Organisation/Company Name</p> <p>If an assessor requires the organisation name that forms part of an existing address to be changed, the assessor must contact the Register Operator using their scheme’s normal procedure for requesting a new address, and ask for this to be done. This will result in a change to the existing, rather than the creation of a new, address.</p> <p>There is one exception to this rule. If a case exists where there are two or more addresses sharing the same details and the organisation / company name is the ONLY unique element of each address, a new address /</p>	
-----------	---	--

Non Domestic EPC Conventions for England & Wales Issue 8

		<p>UPRN is needed.</p> <p>e.g.:</p> <p>The Bookshop, Unit 2, etc...</p> <p>The Cookshop, Unit 2, etc...</p> <p>If an assessor were to ask for one of the above entries to be changed to "The Workshop", a third entry will be added.</p>	
2.09	Acceptable Evidence for High Frequency T8 Lamps	<p>T8 fluorescent lighting can be operated at either low or high frequency and this control option forms part of the SBEM data collection and building performance assessment process.</p> <p>Flicker on the view screens of electronic devices such as cameras or phones may only be used as evidence for low frequency.</p> <p>Where T8 Lamps are being identified as having high frequency operation, as opposed to low frequency, this shall be supported by the use of suitable images and/or documentary evidence in order to identify the operation of the lamps.</p> <p>In cases of inadequate evidence being available, the worst case assumption of low frequency operation shall be assumed.</p>	1 May 2017
2.10	Electric showers in rooms with another source of DHW	<p>Where an electric shower is present and there is another DHW source (other than instantaneous electric which would be treated as the same system) this should be entered as a bivalent system. The other DHW source should be treated as supplying 25% of the demand if it is supplying a hand wash basin only or 50% of the demand if there is also a bath present.</p>	1 July 2018
3. Project Database			
3.01	Light Pipes	<p>The modelling of light pipes using SBEM will only be considered where the pipes do not pass through a complete building storey in order to serve the storey below; in these circumstances consideration should be given to the use of a dynamic simulation model in order to model correctly. Where this is not the case light pipes should be modelled in SBEM as follows:-</p> <ul style="list-style-type: none"> Light pipes will be modelled as roof lights using the glazing type 'Roof light, skylight, twin skin' with 'no frame'. 	1 June 2010 Amended 1 September 2014

Non Domestic EPC Conventions for England & Wales Issue 8

		<ul style="list-style-type: none"> • Additionally, if suitable evidenced number of panes, U values, T solar or L solar values are available, then these should also be utilised. • Automatic daylight zoning will apply. • Each sun pipe should be modelled as a roof light as above, with the area equivalent to the cross sectional area of the light pipe in a horizontal plane, e.g. the area of the circular opening for circular pipes. 	
3.02	Adjacency Assumed - Party Walls	Unless evidence to the contrary is readily and easily available, all buildings adjoining that building or part building which is being assessed, are assumed to be conditioned unless they are of Planning Class B2 to B8 in which case they are assumed to be unconditioned.	1 June 2010
3.03	Frame Factors	<p>The 'Frame Factor' for windows and roof lights within SBEM defaults to a value of 0.1 (10%). The assessor must always establish the frame factor of an actual window or roof light and replace the SBEM default with a more appropriate value - unless 0.1 (10%) is found to be appropriate for the actual window.</p> <p>Where there are multiple windows or roof lights with the same construction and configuration it is only necessary for the assessor to establish the frame factor for a representative example and the same value can be entered for windows or roof lights having the same construction and configuration. The assessor is expected to establish an appropriate frame factor for each distinct set of windows and/or roof lights and not to retain the SBEM default frame factor unless they have shown it to be appropriate.</p> <p>The term "windows" also includes glazed doors being treated as windows.</p>	17 January 2011 Amended 1 May 2017
3.04	Car Parks		Removed from Issue 5 September 2014
3.05	Inadequate or no Fixed Building Services in Existing Buildings		Removed from Issue 2 13 January 2011
3.06	Assumed 'Subsequent Fit out' for Existing		Removed from Issue 2 13 January 2011

Non Domestic EPC Conventions for England & Wales Issue 8

	Buildings										
3.07	Appropriate Use of U and Km Values	<p>In the absence of more specific values the library (or inference) U and Km values for the fabric construction type are used.</p> <p>If an accurate U value or an accurate Km value is available for the specific construction from a suitable source this should be entered to replace the corresponding library (or inference) value.</p> <p>If both the U value and Km value for the specific construction are available from the same source then both should be entered. If not from the same source then only the U value should be used, combined with the library (or inference) Km value.</p> <p>The entry of defined values is only appropriate where the values have been calculated by a Level 4 qualified assessor or other suitably qualified and accredited person\organisation or have been taken from an 'as built' design specification document.</p> <p>Suitable qualification\accreditation is through membership of a recognised U-value calculation competency scheme (BBA/TIMSA (UK), OCDEA membership (England & Wales, Northern Ireland, Scotland) or any other scheme formally agreed between Accreditation Schemes/Approved Organisations and Government.</p> <p>Where U and/or Km values are entered by the assessor, a copy of the documentation stating the introduced values must be provided if called for audit along with evidence of the library (or inference) construction any retained value relates to.</p>	<p>21 January 2013</p> <p>Amended 1 July 2018</p> <p>Amended 1 February 2023</p>								
3.08	Strongly Ventilated Spaces	<p>Where ventilation specifications are available, strongly ventilated spaces shall be defined as such in accordance with the table below:</p> <table border="1"> <thead> <tr> <th>Option</th> <th>Brief Description</th> </tr> </thead> <tbody> <tr> <td>Exterior</td> <td>For an envelope separating the considered zone from the outside air or water</td> </tr> <tr> <td>Strongly ventilated spaces</td> <td>For an envelope separating the considered zone from a space provided with one or more permanent openings (i.e., that cannot be closed), with a capacity for the supply of fresh air and extract of inside air, determined according to section 5.3 of NEN 1087, of at least 3×10^{-3} m³/s per m² useable Area.</td> </tr> <tr> <td>Unheated adjoining space</td> <td>For an envelope separating the considered zone from an unheated adjoining space, other than meant under 'Strongly ventilated spaces'.</td> </tr> </tbody> </table>	Option	Brief Description	Exterior	For an envelope separating the considered zone from the outside air or water	Strongly ventilated spaces	For an envelope separating the considered zone from a space provided with one or more permanent openings (i.e., that cannot be closed), with a capacity for the supply of fresh air and extract of inside air, determined according to section 5.3 of NEN 1087, of at least 3×10^{-3} m ³ /s per m ² useable Area.	Unheated adjoining space	For an envelope separating the considered zone from an unheated adjoining space, other than meant under 'Strongly ventilated spaces'.	<p>21 January 2013</p>
Option	Brief Description										
Exterior	For an envelope separating the considered zone from the outside air or water										
Strongly ventilated spaces	For an envelope separating the considered zone from a space provided with one or more permanent openings (i.e., that cannot be closed), with a capacity for the supply of fresh air and extract of inside air, determined according to section 5.3 of NEN 1087, of at least 3×10^{-3} m ³ /s per m ² useable Area.										
Unheated adjoining space	For an envelope separating the considered zone from an unheated adjoining space, other than meant under 'Strongly ventilated spaces'.										

Non Domestic EPC Conventions for England & Wales Issue 8

		<table border="1"> <tr> <td>Conditioned adjoining space</td> <td>For an envelope separating the considered zone from another conditioned zone.</td> </tr> <tr> <td>Underground</td> <td>For an envelope separating the considered zone from the ground.</td> </tr> <tr> <td>Same space</td> <td>For constructions representing the internal envelopes that separate contiguous zones which have been merged into one zone, i.e., the envelope is “contained” within the merged zone.</td> </tr> </table> <p>iSBEM User Guide (February 2012): Table 9: Options for ‘Connects space to’ field for envelopes</p> <p>Note that a strongly ventilated space is an alternative to an unheated adjoining space only and is not selected in any other circumstances. Where appropriate ventilation specifications are unavailable, a zone will be considered to be a strongly ventilated space if it is unheated and is one of the following:-</p> <ol style="list-style-type: none"> 1. Any part of the building being assessed that is identified with the activity of ‘car park’ 2. Any non-heated/cooled industrial process area that has mechanical extraction/ventilation serving the whole of the zone in order to accommodate the on-going processes. 3. Any area that has deliberate fixed openings in order to provide significant natural ventilation, e.g.: <ol style="list-style-type: none"> a. A plant room with louvered doors / vents for provision of combustion air b. A naturally ventilated internal, underground or basement store area with fixed openings <p>Note that windows that are left permanently open are not categorised as fixed openings. If in any doubt, the assessor is to assume the presence of a strongly ventilated space as a worst case default position. Site notes/evidence to be provided accordingly.</p>	Conditioned adjoining space	For an envelope separating the considered zone from another conditioned zone.	Underground	For an envelope separating the considered zone from the ground.	Same space	For constructions representing the internal envelopes that separate contiguous zones which have been merged into one zone, i.e., the envelope is “contained” within the merged zone.	
Conditioned adjoining space	For an envelope separating the considered zone from another conditioned zone.								
Underground	For an envelope separating the considered zone from the ground.								
Same space	For constructions representing the internal envelopes that separate contiguous zones which have been merged into one zone, i.e., the envelope is “contained” within the merged zone.								
3.09	Transparent Curtain Walling	<p>The description of ‘curtain walling’ in the SBEM database refers to solid or opaque wall construction only and therefore the U and Km values applied to this construction type do not include areas of glazing or translucent materials within the wall space.</p> <p>Areas of glazing or translucent material within a curtain wall should be treated as glazed areas and assessed following the SBEM methodology and iSBEM User Manual. See also ‘Dimensions Convention 10.03’.</p>	21 January 2013						

Non Domestic EPC Conventions for England & Wales Issue 8

3.10	Appropriate Activity Selection for Animals Housed Overnight	<p>For activities such as veterinary or similar building where space for housing animals is conditioned on a 24 hour basis 7 days a week, assessors should use the “C2A Secure Residential Institutions” as the building type and select the “Cell (police/prison)” as the activity type (the temperature values for this activity type are the closest to those associated with housing animals overnight).</p> <p>For veterinary and similar buildings where there is no overnight stay or storage for animals then “C2 Residential Institutions - Hospitals and Care Homes” should be used at zone level and the animal holding area should be assessed as ‘store room’.</p> <p>Except where specific factors require otherwise (evidence will be required):</p> <ol style="list-style-type: none"> 1. For buildings such as kennels or catteries where the main purpose is housing animals, the overall building type should be “C2A Secure Residential Institutions”. 2. For buildings such as veterinary surgeries (where the main use profile is similar to that of a doctors’ or dentists’ surgery) the overall building type should be “D1 Non-residential institutions – Primary healthcare building”. <p>Within either type of building:</p> <ol style="list-style-type: none"> a) Where animals are housed overnight the activity is expected to require conditioning on a 24 hour basis 7 days a week. Assessors should use building type “C2A Secure Residential Institutions” and “Cell (police/prison)” as the activity for the animal holding area. b) Where animals are housed during working hours but are not kept overnight, assessors should use building type “C2 Residential Institutions - Hospitals and Care Homes” and “Store room” as the activity for the animal holding area. 	1 September 2014 Amended 1 February 2023
3.11	Secondary Glazing	<p>Where secondary glazing is present in existing buildings, select from the Project database Library the following option:-</p> <p>Acoustic double glazing with 200mm interpane gap.</p> <p>The frame type shall be the framing material used for the outer pane only.</p>	1 September 2014

Non Domestic EPC Conventions for England & Wales Issue 8

3.12	Multiple Window Frame Types	Where any window has frames made of multiple frame types, e.g. timber outer frame and metal intermediate frames, the assessor shall select the frame type for the material that is in direct contact with the structural opening.	1 September 2014										
3.13	Sales vs Eating & Drinking Activity Selection	<p>As a first step Assessors should work to the descriptions provided by BRE in the iSBEM interface. The following statements provide additional guidance for specific circumstances:-</p> <ol style="list-style-type: none"> 1. For small food outlets and hot food takeaways in Classes A3, A4 & A5, the Eating/drinking activity should only be applied to areas that are designated for the purpose of eating and drinking i.e. that include tables (or counters) and chairs and are located <i>inside</i> the premises, otherwise the zone will be classified as a sales area. An example would be a pizza outlet that is predominantly take away and delivery but which provides a small designated area with tables and chairs in the shop area which could be designated as an eating/drinking area. 2. Generic Office Areas should include any tea room / tea making facilities, kitchenettes and staff lounges. These areas should not, therefore, be identified as eating and drinking areas. <p>Please see the glossary section (10.08) for the list of all building types with the activity of 'Eating/drinking area' and their description.</p>	1 May 2017										
3.14	Block Glazing Exteriors	<p>Glass Blocks should be entered in accordance with the following hierarchy:-</p> <ol style="list-style-type: none"> (1) Where any external walls or parts thereof, are constructed of Glass Blocks they should be entered as Windows. (2) Where the specification for the building refers to specific glass blocks and the supporting technical information of the glass blocks are available then the U-Values, T-Solar and L-Solar values should be entered as User defined Values. The specification and technical information must be provided as part of the evidence to support the use of this option. (3) Where the specification and/or the technical information is not available then the following user defined U-Values, T-Solar and L- Solar values should be entered. <table border="1" data-bbox="555 1321 1518 1417"> <thead> <tr> <th>Build Date</th> <th>U- Value W/m2K</th> <th>T Solar</th> <th>L Solar</th> <th>Frame Factor</th> </tr> </thead> <tbody> <tr> <td>Buildings Built pre 2002</td> <td>3.2 ⁽⁴⁾</td> <td>0.83 ⁽²⁾</td> <td>0.8 ⁽¹⁾</td> <td>0.00</td> </tr> </tbody> </table>	Build Date	U- Value W/m2K	T Solar	L Solar	Frame Factor	Buildings Built pre 2002	3.2 ⁽⁴⁾	0.83 ⁽²⁾	0.8 ⁽¹⁾	0.00	1 May 2017
Build Date	U- Value W/m2K	T Solar	L Solar	Frame Factor									
Buildings Built pre 2002	3.2 ⁽⁴⁾	0.83 ⁽²⁾	0.8 ⁽¹⁾	0.00									

Non Domestic EPC Conventions for England & Wales Issue 8

		Buildings Built post 2002	2.2 ⁽⁵⁾	0.71 ⁽²⁾	0.8 ⁽¹⁾	0.00	
4. Geometry							
4.01	Light Wells	Light wells to be treated as external envelopes.					1 June 2010
4.02	Atria	All atria to be treated as Level 5 NDEPC assessment feature. Refer to accompanying Level 3, Level 4 and Level 5 decision flowchart and notes (Issue 1 – 15 March 2010).					1 June 2010
4.03	Dimensions	Horizontal and vertical (inc. zone height) measurements to be carried out in accordance with diagrams and notes in 'CEPC Dimension Conventions' documentation.					1 June 2010
4.04	Measurement Accuracy (for Distance, Area and Volume)	<p>Calculated values entered into the software for the purpose of an EPC calculation must be provided with supporting calculations presented for audit.</p> <p>The minimum level of accuracy for calculated values entered into the software for the purpose of an EPC calculation is 2 decimal places i.e. 2 places after the decimal point for any given value.</p> <p>All measurements entered into the software must be recorded to at least 2 decimal places on site notes.</p> <p>Where the required level of measurement accuracy is not possible the reason must be recorded.</p>					21 January 2013
4.05	Roofs with Multiple Components	<p>Where the external roof of a zone or an individual component has a horizontal internal ceiling, the roof shall be entered as having a horizontal orientation and the area of the roof shall be the total horizontal internal surface area exposed to the conditioned space. The roof pitch angle shall be entered as the SBEM default of 45 degrees. See 'Roofs with Multiple Components 10.06: Horizontal internal ceiling (Examples 1 and 2)'.</p> <p>Where a horizontal internal ceiling is not present, the roof area shall be that of the internal surface area exposed to the conditioned space and the orientation shall be the compass position that is 'faced' by the pitched component. The pitch angle shall be the angle of the component to the horizontal. See 'Roofs with Multiple Components 10.06: No horizontal internal ceiling'.</p> <p>Where a roof structure is constructed of a number of pitched components then each shall be addressed individually and entered as separate components as part of the model, however if individual components have exactly the same set of properties they can be entered as one envelope comprising of the sum area of the components. See 'Roofs with Multiple Components 10.06: Roof structure with number of pitched</p>					21 January 2013

Non Domestic EPC Conventions for England & Wales Issue 8

		components’.	
4.06	Same Space Adjacency	Internal wall envelope areas, of the same or similar construction, within merged zones may be added together and entered as a single envelope area, attached to the merged zone, with the adjacency of “Same space”. The orientation of the envelope is not relevant to the EPC results and calculations for the ‘Same space’ envelope should be documented for audit purposes.	1 May 2017
4.07	Zoning for Day Lit Spaces	<p>All zones must be evaluated for ‘day lit’ spaces which will need to be identified and entered into the software model as separate zones.</p> <p>In many circumstances approved software tools offer an option for day lit zones to be calculated automatically which requires no subdivision of the spaces by the assessor.</p> <p>The method below must be used to subdivide zones for day lit areas where the option for automatic calculation is not selected, not available or where manual day lit zoning is prescribed as required within conventions.</p> <p>Divide building areas, already identified as ‘zones’, to account for areas receiving significantly different amounts of daylight, defined by boundaries which are:</p> <ul style="list-style-type: none"> • At a distance of 6m from an external wall containing at least 20% glazing • At a distance of 1.5 x room heights beyond the edge of an array of roof-lights if the overall area of the roof-lights is at least 10% of the zone floor area <p>Note:</p> <ol style="list-style-type: none"> 1) If any resulting zone is less than 3m wide, absorb it within surrounding zones with the same HVAC, lighting and activity 2) If any resulting zones overlap, use your discretion to allocate the overlap to one or more of the zones 3) In all cases where a zone is sub-divided to identify day lit spaces all other zone features such as HVAC, activity and lighting will be applied to each of the subdivided zones 	<p>1 May 2017</p> <p>Amended 1 July 2018</p>
4.08	Modelling a Zone Within a Zone	<p>Notes to Support Diagram Below</p> <p>Z1a – Full height part of the outer zone – Height = 5.00m</p> <p>Z1b – Part of the outer zone extending over the inner zone - Height = 3.00m</p>	<p>1 May 2017</p> <p>Amended 1 July 2018</p>

Non Domestic EPC Conventions for England & Wales Issue 8

Z2 – Inner zone – Height = 2.00m

The floor of Z1b is only included in the floor area of the EPC if it has permanent access and is a usable floor area but it must always be modelled as an envelope.

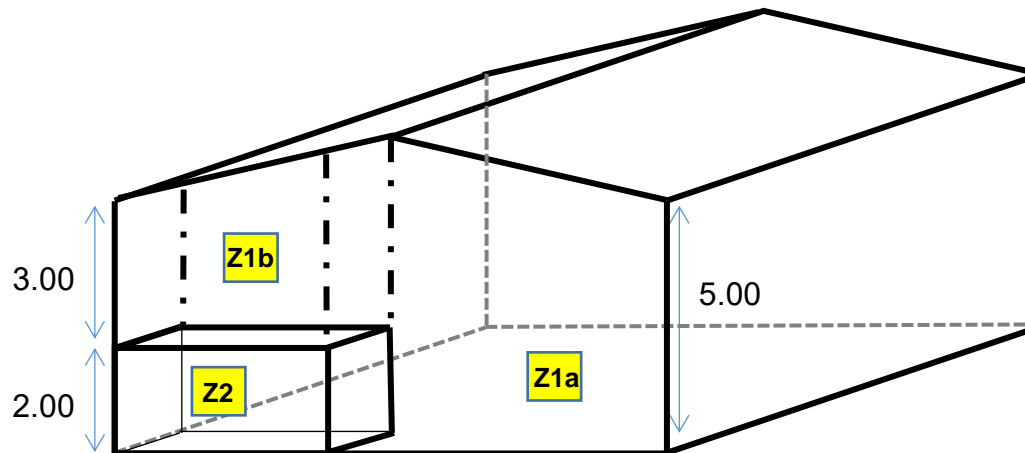

Convention Text

This convention applies where a separate zone (Zone 2) enclosed by walls, doors, ceilings and/or windows, exists within the envelope of a larger space or building (Zone 1), at least one of the boundary walls of Zone 1 forms the boundary wall to Zone 2 (and there is a view of the walls of Zone 1 where it extends above Zone 2). A typical scenario would be where there is an office or toilet block (Zone 2) in the corner of an industrial unit or warehouse (Zone 1).

The floor envelope of Z1b must be entered to take account of the heat transfer and thermal mass. However, it must only be included as floor area on the EPC if it has permanent fixed access and it is a useable floor space in accordance with the definition of GIA from RICS Code of measuring practice.

For the purposes of modelling this scenario in SBEM

If the space above Zone 2 is accessible floor area, Zone 1a and Zone 1b are entered as two separate zones which can have different properties if applicable.

If the space above Zone 2 is not accessible floor area Zone 1a and Zone 1b are entered as a single zone and will have the same properties. The floor area of Zone 1b is not to be included in the zone area. (The

Non Domestic EPC Conventions for England & Wales Issue 8

		method of achieving this will vary depending upon the approved software used).	
5. Global Building Services			
5.01	Electric Power Factor	<p>Electric power factor within SBEM must be left at the default value of <0.9 unless you have provided a photograph of the power factor correction device and/or other compelling evidence to amend this figure.</p> <p>Where only a photograph of the power factor correction device is available the power factor shall be amended to '0.9 to 0.95'.</p> <p>Compelling evidence includes the following:-</p> <ul style="list-style-type: none"> • Photographic evidence; if the photograph can confirm the actual power factor figure from the device, then select the most appropriate figure within the SBEM power factor drop down options. If the photograph cannot confirm the actual figure but shows evidence of the power factor device, then the assessor shall select the option of '0.90-0.95' within SBEM for the power factor value. • Equipment specifications; name-plates, specification manuals and printouts from Building Mechanical Services (BMS) systems. • Utility bills. • Power factor calculations; conducted by electricians and power engineering specialists. • Meter readings; incorporating reactive unit consumption and appropriate calculations. 	21 January 2013
6. HVAC			
6.01	Variable Speed Pumps Other than Central Heating	Ignored unless using approved DSM software which allows for this input option.	1 June 2010
6.02	Passive Stack Ventilation	Treat as per natural ventilation	1 June 2010
6.03	Electric Room Heaters	Any form of fanned or unfanned electric 'room heater' whether panel, bar, convactor or storage heater shall have a user amended efficiency of 1 (i.e. 100%).	1 June 2010

Non Domestic EPC Conventions for England & Wales Issue 8

6.04	LTHW Boiler Efficiencies	<p>The following hierarchy should be followed to establish suitable values for the 'Effective Heat Generating Seasonal Efficiency' for all boilers.</p> <ol style="list-style-type: none"> 1. Use Enhanced Capital Allowance (ECA) product list part load values at 30% and 100%* - these should be used to calculate the seasonal efficiency as per the Non Domestic Building Services Compliance Guide (NDBSCG). 2. Use ECA product list full load value* (when part load values are not given). 3. Use current PCDB values where available. 4. Use either manufacturer's information* or 'boiler plate*' information or information from manufacturer's technical helpdesk*. Where a gross efficiency value is established for a non condensing boiler then a deduction of 0.05 (i.e. 5%) should be made to it to convert it to an appropriate seasonal efficiency. 5. Use SAP 2005 tables (up to 70kW output). 6. Use suitable SBEM default; it is essential for the site notes to provide evidence as to why the above methods were not used to obtain a more accurate value, i.e. by providing evidence of failed attempts. <p>In addition to any boiler efficiency values established from the above the relevant heating credits should be added by following the guidance in the NDBSCG.</p> <p>*Net efficiencies/values must be converted to gross efficiencies as per the NDBSCG.</p>	<p>17 January 2011</p> <p>Amended 1 May 2017</p> <p>Amended 1 February 2023</p>
6.05	Electric HWS with and Without Storage	<p>Where an electric system has no storage then it should be entered as an 'instantaneous system' with grid supplied electricity as its fuel and a seasonal efficiency of 1 (i.e. 100%).</p> <p>Where an electric system has some/any storage then 'electric instantaneous system' should NOT be used and 'Stand-alone water heater' should be used. Where such a system also has its losses or volume and insulation details entered then the efficiency of the system should be 1 (i.e. 100%).</p>	17 January 2011
6.06	HWS Efficiencies and Storage Losses	<p>The presence of storage/losses MUST be entered for all storage systems and this should be done where possible by entering the losses (in MJ/month) in preference to the volume and insulation type and thickness. The source information (such as manufacturer's data) and/or calculation must be included in site notes.</p> <p>Where losses cannot be established then the volume and insulation details should be entered.</p> <ul style="list-style-type: none"> • Where the volume and/or insulation cannot be established via external visual inspection and/or paperwork they should be estimated as follows: <ul style="list-style-type: none"> ○ For a modern steel or plastic encased unvented pressurised hot-water cylinder larger than 50 litres (e.g. Megaflo), enter insulation as 50 mm factory insulated and calculate the volume based on external dimensions less 50mm of insulation. 	<p>17 January 2011</p> <p>Amended 1 July 2018</p>

Non Domestic EPC Conventions for England & Wales Issue 8

		<ul style="list-style-type: none"> ○ For a modern steel or plastic encased unvented pressurised hot-water cylinder up to 50 litres, or electric multipoint, enter insulation as 25 mm factory insulated and calculate the volume based on external dimensions less 25mm of insulation. ○ For a modern steel or plastic encased point of use water heater (typically over/under sink up to 10 litres) enter insulation as 10 mm factory insulated and calculate volumes based on external dimensions less 10mm of insulation. ○ For other types of HWS storage the external dimensions of the unit will be used as if the storage vessel completely fills the unit with no deduction for insulation thickness and where the insulation type cannot be established via survey and/or paperwork it should be assumed to be uninsulated. ● Where details of the HWS are unavailable or there is no system then the HWS shall be entered as an 'instantaneous system' with no storage with a seasonal efficiency of 0.5 (i.e. 50%). Where the fuel type can be readily determined then the appropriate fuel type must be entered otherwise 'grid electric' should be assumed. ● Where the DHW serves multiple buildings, the losses should be apportioned between those buildings based on floor area. <ul style="list-style-type: none"> ○ If the losses are not known so volume and insulation details are being used the volume cannot be apportioned between the buildings. The assessor should initially run the SBEM calculation allocating all of the storage to the building being assessed and look up the Calculated SBEM value for Storage losses. This figure should then be apportioned between the buildings based on floor area and entered as the Storage losses MJ/month. 	
6.07	Estimating Local Mechanical Exhaust Rates in Buildings	Where it is not possible to obtain details of the fan performance from the Fan nameplate or Building Logbook, Operation & Maintenance manual etc. during the Site Survey, an approximation of the of the air flow rate in $\text{l s}^{-1} \text{m}^{-2}$ (often written as l/s/m^2 in SBEM) can be established by using an appropriate rate from the attached table (Local Mechanical Exhaust Rates) and converting this to $\text{l s}^{-1} \text{m}^{-2}$, using the zone height (do not adjust the height measurement used to compensate for an internal ceiling). It is not acceptable to use an arbitrary value such as $5 \text{ l s}^{-1} \text{m}^{-2}$ or a software applied default for extraction rates where the mechanical extraction rate is unknown.	17 January 2011 Amended 30 November 2012 Amended 1 July 2018
6.08	Estimating the Local Mechanical Exhaust	Note: if assessing kitchen area extraction or ventilation please refer to convention 6.12 Where the fan power motor can be established from the fan nameplate or Building Logbook, Operation & Maintenance manual etc. during the site survey the established power will be used to calculate the SFP.	17 January 2011 Amended 1

Non Domestic EPC Conventions for England & Wales Issue 8

<p>Specific Fan Power (SFP) in Existing Buildings</p>	<p>If the power rating of a fan is known in horsepower then it shall be converted using the approximation of 1 horsepower = 746 Watts</p> <p>Where specific fan performance details are not available, the W/l/s value shall be amended as follows for existing buildings:-</p> <p>1.5 W/l/s – buildings built to Building Regulations pre 2006 (pre 2007 in Scotland) 0.5 W/l/s – buildings built to 2006 Building Regulations (2007 in Scotland) 0.4 W/l/s – buildings built to 2010 Building Regulations (or later)</p> <p>For <u>Local Mechanical Extract</u> systems only</p> <p>0.5 W/l/s - buildings built to 2006 Building Regulations (2007 in Scotland) 0.4 W/l/s - buildings built to 2010 Building Regulations 0.3 W/l/s - buildings built to 2013- Building Regulations (or later)</p> <p>For <u>Mechanical Ventilation</u> systems, whether defined at system level or at zone level</p> <p>2.5 W/l/s - buildings built to 2006 Building Regulations (2007 in Scotland) 1.8 W/l/s - buildings built to 2010 Building Regulations 1.6 W/l/s - buildings built to 2013- Building Regulations (or later)</p> <p>In addition to any specific fan powers established from the above, the relevant additional components from table 36 below should be added by following the guidance in the 2013 Non Domestic Building Services Compliance Guide.</p> <div data-bbox="472 1023 1727 1406" style="background-color: #e0e0e0; padding: 10px;"> <p>Table 36 Extending specific fan power for additional components in new and existing buildings</p> <table border="1"> <thead> <tr> <th>Component</th> <th>SFP (W/(l·s))</th> </tr> </thead> <tbody> <tr> <td>Additional return filter for heat recovery</td> <td>+0.1</td> </tr> <tr> <td>HEPA filter</td> <td>+1.0</td> </tr> <tr> <td>Heat recovery – thermal wheel system</td> <td>+0.3</td> </tr> <tr> <td>Heat recovery – other systems</td> <td>+0.3</td> </tr> <tr> <td>Humidifier/dehumidifier (air conditioning system)</td> <td>+0.1</td> </tr> </tbody> </table> </div>	Component	SFP (W/(l·s))	Additional return filter for heat recovery	+0.1	HEPA filter	+1.0	Heat recovery – thermal wheel system	+0.3	Heat recovery – other systems	+0.3	Humidifier/dehumidifier (air conditioning system)	+0.1	<p>September 2014</p> <p>Amended 1 May 2017</p> <p>Amended 1 February 2023</p>
Component	SFP (W/(l·s))													
Additional return filter for heat recovery	+0.1													
HEPA filter	+1.0													
Heat recovery – thermal wheel system	+0.3													
Heat recovery – other systems	+0.3													
Humidifier/dehumidifier (air conditioning system)	+0.1													

Non Domestic EPC Conventions for England & Wales Issue 8

		The energy assessor should provide in assessment notes the reason why specific fan performance is not available.	
6.09	Reversible Extract Fans	Reversible extract fans are treated in the same way as non-reversible extract fans in SBEM. It is not acceptable to use an arbitrary value or software default for the extraction rate where the actual value is unknown. Refer to 'Estimating Local Mechanical Exhaust rates in existing buildings 6.07', to calculate the extraction rate, if necessary.	1 February 2012
6.10	Hot Water Storage Vessels	<p>Hot Water Storage Vessels Where you have a number of hot water storage vessels that have exactly the same fuel type and efficiency of operation, these can be entered into SBEM as one system incorporating the sum total of the storage losses of the individual storage vessels. In these circumstances it is permissible to aggregate vessels of different sizes as long as the storage losses are known for all individual vessels.</p> <p>Storage vessels that are identified by the insulation type cannot be aggregated as the SBEM model derives an assumption for the storage losses based upon insulation type and vessel size in these circumstances.</p> <p>Individual systems that vary by way of recirculation systems or by the use of CHP or solar energy cannot be aggregated and should be entered separately.</p> <p>Instantaneous Hot Water Systems Multiple instantaneous systems having the same fuel type and assumed efficiency can simply be entered as one system and allocated to all zones as appropriate.</p>	1 February 2012
6.11	Zones Without Fixed Conditioning Equipment in Existing Buildings	<p>This convention only applies where at least one zone within the building is not conditioned by fixed conditioning equipment, e.g. heating, cooling or mechanical ventilation.</p> <p>The flow chart below ('zones without fixed conditioning equipment' - appendix 10.07) provides the approach an energy assessor should take in these circumstances. Energy assessors should ensure that they can provide evidence to justify the option selected at each decision point in the flow chart.</p> <p>Zones must be assessed as seen on the day of the inspection. However, for the purposes of this convention the SBEM activity types where zones may not be conditioned (i.e. where no HVAC systems are present) are as follows:</p> <ol style="list-style-type: none"> a. Circulation Areas b. Plant rooms c. Store rooms and Warehouse Storage 	<p>1 September 2014</p> <p>Amended 1 May 2017</p> <p>Amended 1 July 2018</p>

Non Domestic EPC Conventions for England & Wales Issue 8

		<p>d. Industrial process area e. Car park f. B1 Workshops g. Toilet (only if there are no other zones in the building that have an expectation of conditioning)</p> <p>In these circumstances, the SBEM HVAC type will be identified as 'Zones without HVAC system'.</p>																	
6.12	Kitchen Area Extraction	<p>All kitchen area extraction or mechanical ventilation equipment is to be included as part of the SBEM assessment process, in order to account for the additional energy requirements for the conditioning of higher air change rates. i.e. extractor hoods are no longer to be disregarded and are to be assessed as part of the extraction rate for the zone(s) concerned.</p> <p>If performance details of extraction units are unknown then defaults should be assumed in accordance with CL6.07 'Estimating Local Mechanical Exhaust rates in existing buildings' with the following table provided for additional guidance:-</p> <table border="1"> <thead> <tr> <th>Description</th> <th>SBEM Activity</th> <th>CEPC 6.07 Vent Room Type</th> <th>Assumed Extract Rate a/c per hour</th> </tr> </thead> <tbody> <tr> <td>Small kitchen or kitchenette or tea making facility with a single wall or window extractor fan only. Very limited food preparation activities taking place</td> <td>Generic Office (was Tea Making)</td> <td>Tea making</td> <td>10</td> </tr> <tr> <td>'Domestic' type kitchen with a single cooker hood extraction unit and/or a single wall or window extractor fan and limited food preparation activities</td> <td>Food preparation</td> <td>Kitchen – domestic</td> <td>15</td> </tr> <tr> <td>'Non-domestic' kitchen with multiple cooker hood extraction and / or multiple wall or window extraction units Extensive food preparation activities, e.g. kitchen serving restaurant,</td> <td>Food preparation</td> <td>Kitchen – non-domestic</td> <td>40</td> </tr> </tbody> </table>	Description	SBEM Activity	CEPC 6.07 Vent Room Type	Assumed Extract Rate a/c per hour	Small kitchen or kitchenette or tea making facility with a single wall or window extractor fan only. Very limited food preparation activities taking place	Generic Office (was Tea Making)	Tea making	10	'Domestic' type kitchen with a single cooker hood extraction unit and/or a single wall or window extractor fan and limited food preparation activities	Food preparation	Kitchen – domestic	15	'Non-domestic' kitchen with multiple cooker hood extraction and / or multiple wall or window extraction units Extensive food preparation activities, e.g. kitchen serving restaurant,	Food preparation	Kitchen – non-domestic	40	<p>1 September 2014</p> <p>Amended 1 February 2023</p>
Description	SBEM Activity	CEPC 6.07 Vent Room Type	Assumed Extract Rate a/c per hour																
Small kitchen or kitchenette or tea making facility with a single wall or window extractor fan only. Very limited food preparation activities taking place	Generic Office (was Tea Making)	Tea making	10																
'Domestic' type kitchen with a single cooker hood extraction unit and/or a single wall or window extractor fan and limited food preparation activities	Food preparation	Kitchen – domestic	15																
'Non-domestic' kitchen with multiple cooker hood extraction and / or multiple wall or window extraction units Extensive food preparation activities, e.g. kitchen serving restaurant,	Food preparation	Kitchen – non-domestic	40																

Non Domestic EPC Conventions for England & Wales Issue 8

		<table border="1" data-bbox="465 185 1458 248"> <tr> <td data-bbox="465 185 799 248">canteen, residential schools, colleges etc.</td> <td data-bbox="799 185 1043 248"></td> <td data-bbox="1043 185 1252 248"></td> <td data-bbox="1252 185 1458 248"></td> </tr> </table> <ul style="list-style-type: none"> ● SFP = 0.4 for the circumstance where the fan is within the zone ● SFP = 0.6 where the fan is outside the zone. <p>Assessors should endeavour to obtain and utilise the performance details of all extraction equipment identified as part of their assessment in accordance with CL6.07 within Conventions Issue 2 with convention 6.07. However, where it is not possible to identify all of the equipment in any given zone, the defaults shown in the table above for 'Assumed Extract Rate' shall be used.</p> <p>In addition, in order to remove a degree of the “process power” of the fan itself, the assessor should select the following additional default exhaust specific fan power values:-</p> <ul style="list-style-type: none"> ● SFP = 0.4 for the circumstance where the fan is within the zone ● SFP = 0.6 where the fan is outside the zone. <p>For Local Mechanical Extract systems only</p> <ul style="list-style-type: none"> • SFP = 0.4 for the circumstance where the fan is within the zone • SFP = 0.6 where the fan is outside the zone. <p>For Mechanical Ventilation systems, whether defined at system level or at zone level</p> <ul style="list-style-type: none"> • SFP = 0.8 for circumstance where the SFP is unknown • SFP = entered as 50% of the actual SFP in order to remove the “process power” element <p>Even if the SFP is defined at system level, it only applies to the kitchen zone.</p>	canteen, residential schools, colleges etc.				
canteen, residential schools, colleges etc.							
6.13	Identifying Indirectly Conditioned Zones	<p>Where a zone is without any form of fixed conditioning equipment, but at least 50% of the surrounding envelope area excluding including party walls, party floors and party ceilings is adjacent to directly conditioned space, (or for party envelopes is assumed to be adjacent to conditioned space), then it will be assumed to be indirectly conditioned.</p> <p>The zone will be assigned the same HVAC as the adjacent spaces, or the larger proportion of adjacent spaces unless there is significant air transfer with a specific adjacent zone, for example through a frequently used doorway.</p> <p>The energy assessor should provide suitable evidence to show that there is no fixed / direct conditioning</p>	<p>1 September 2014</p> <p>Amended 1 July 2018</p> <p>Amended 1 February 2023</p>				

Non Domestic EPC Conventions for England & Wales Issue 8

		<p>equipment within the zone and that at least 50% of the surrounding area is conditioned, i.e. a floor plan and/or photos of the unconditioned zone.</p> <p>A zone which has no fixed conditioning equipment but is being treated as “conditioned adjoining space” by applying assumed heating following convention 6.11 and appendix 10.07 is NOT considered to be directly conditioned and cannot contribute to indirectly conditioning any adjacent zone. IS considered to be directly conditioned and does contribute to indirectly conditioning any adjacent zone.</p>	
	Individual Shop Units in Shopping Centres	<p>There are three scenarios that should be dealt with when assessing a locally and centrally conditioned individual shop in a shopping centre:</p> <ol style="list-style-type: none"> 1. The unit has local heating or Air Conditioning and receives unconditioned central fresh air from the plant room. This unit should be assessed in SBEM with the local heating plus ‘mechanical ventilation’ to the affected zones. The level of assessment will depend on the type of system conditioning the room. Please refer to assessment level decision flowchart (10.02). 2. The unit has local heating or Air Conditioning and tempered fresh air from a central location. This unit should be modelled as item 1 above. 3. The unit is supplied by a centrally conditioned system in addition to local devices. In these circumstances the following should be followed:- <p>The zone should be split into a number of zones to match the number of HVAC types. All of the zone’s envelopes, including glazing, should be equally split and entered into each relevant zone along with the appropriate respective HVAC type.</p> <p>(Note – it may not be possible for all of the zone’s envelopes, including glazing to be equally split in approved software versions using a graphical interface. If this is the case the zone, its envelopes and glazing should be divided as equally as possible and the limitation recorded on site notes).</p>	<p>1 September 2014</p> <p>Amended 1 July 2018</p>
6.15	Bivalent system proportioning within a building zone	<p>Where a bivalent system i.e. 'One in which the heating is supplied by two (or more) different types of heat source' is present in a zone within the building under assessment, entries are required to specify the proportion of load met by each of the systems present. This must be determined on a 'zone by zone' basis i.e. the same HVAC system can only be assigned to multiple zones when the source(s) and delivery method(s) are the same. The Assessor is required to enter the proportion of heating load that the additional (bivalent) heat generator(s) provide and the balance is assigned to the main system.</p> <p>When a bivalent system is entered the Assessor can apply any control corrections to each of the system efficiencies as appropriate. It is only however possible to select one set of control options. These should be</p>	1 July 2018

Non Domestic EPC Conventions for England & Wales Issue 8

		<p>selected as appropriate to the system which supplies the greatest heating load.</p> <p>Any system which provides cooling must be entered as the main system. When none of the systems provide cooling the main system should if possible be the one which supplies the greater proportion of heating load.</p> <ol style="list-style-type: none"> 1. The software will only account for cooling from the main system and the main system does not need to be the one which supplies the greater proportion of heating load in this instance. 2. Where there is evidence of the relative heating load e.g. a 'heating load design' this should be used. 3. Where the relative heating load is unknown the following principles shall be applied: <ol style="list-style-type: none"> a) One central (multi-zone system) and one or more local (single zone) system(s): <ul style="list-style-type: none"> - 80% is assigned to the central system and 20% to the local system (or equally divided between the local systems). b) Two central (multi zone) systems only: <ul style="list-style-type: none"> - 50% is assigned to each system. c) Two central (multi zone) systems and one or more local (single zone) system(s): <ul style="list-style-type: none"> - 40% is assigned to each central system and 20% to the local system (or equally divided between the local systems). d) No central (multi zone) system and two or more local (single zone) systems: <ul style="list-style-type: none"> - load is equally assigned to each local system. <p>For the purpose of this convention a split or multi split is considered to be a local system.</p>	
7. Lighting			
7.01	Lighting Options in SBEM	<p>If a building's original lighting design is available, and there is no discrepancy between that and the observed lighting within the building, the wattage and lux values, from that design, should be entered using the 'Full lighting design carried out' option in SBEM. If complimentary values are not available (i.e. both values from the same lighting design) the lighting design(s) must not be used.</p> <p>If the circuit wattage and lux levels can be accurately recorded by the assessor (see 'Use of Lux Level Meters 7.02') the option for 'Full lighting design carried out' should also be used and the appropriate values entered. Wattage and lux values must not be entered separately nor is it acceptable to input assumed</p>	<p>17 January 2011</p> <p>Amended 1 February 2023</p>

Non Domestic EPC Conventions for England & Wales Issue 8

		<p>wattage or lux values from BSRIA publications or other reference documents or to accept or use software suggested default value.</p> <p>If the circuit wattage and lux values cannot be ascertained by either of the above methods it may be possible to use the 'Lighting chosen but calculation not carried out' option where BOTH the lumens per circuit wattage (lm/cw) and light output ratio (LOR) must be entered, calculated in line with building regulations guidance. This may not be possible for all zone activity selections. The evidence of how any values used have been obtained must be provided in the site notes.</p> <p>a) If the lm/cw are known for the entire light fitting including the integral lamp(s) or LED chip(s) the LOR is 1</p> <p>b) If the lm/cw are known for the lamp the LOR for the luminaire also must be obtained in order to use this information; except in the case of directional (downlight type) lamps which are not shielded by the luminaire or behind a diffuser in which case the LOR is 1</p> <p>c) A "bulb" type lamp is not directional, so the LOR cannot be assumed to be 1 even if the bulb is not within a fitting or shade.</p> <p>If none of the above options are applicable the 'Lighting parameters not available' option should be chosen and the appropriate lamp type for the zone should be selected. For zones with a mixture of lamp types please see 'Mixed lighting in a zone 7.03'.</p> <p>If no lamps are present, please see 'Missing Lamp Selection 7.05'.</p>	
7.02	Use of Lux Level Meters	<p>Lux level readings, taken by an assessor, may only be used for the production of an EPC if the readings have been recorded in line with the Society of Light & Lighting's Code for Lighting 2009. Evidence of achieving a complete blackout of windows and the required calculations to establish the grid size for the measurements taken must be provided.</p>	17 January 2011
7.03	Mixed Lighting in a Zone in SBEM	<p>Where a zone contains both general lighting and display lighting, and for the selected activity SBEM assumes the presence of display lamps, then the display lighting and the general lighting must be entered as 'display' and 'general' lighting respectively.</p> <p>Where a zone contains both general lighting and display lighting, and for the selected activity SBEM does not assume the presence of display lamps, then the zone must be subdivided to create additional 'display' zones to represent the display lighting. A suitable 'display' activity should be used for the 'display' zones and appropriate lighting entries entered. The remains of the original zone must have the original activity and only the general lighting is entered into the zone(s).</p> <p>Where a zone contains a mixture of lamp types providing general lighting (no display lighting) across the entire zone, such that simply splitting the zone to reflect the lamp's locations is not practicable, then the following method should be followed:</p>	<p>17 January 2011</p> <p>Amended 1 May 2017</p>

Non Domestic EPC Conventions for England & Wales Issue 8

		<ol style="list-style-type: none"> 1. The proportion of the zone's area lit by each lamp type should be established. 2. The zone should then be split into a number of zones to match the number of lamp types and for each lamp type the relevant proportion of the zone area and all of the zone's envelopes, including glazing, should be entered into each relevant zone along with the appropriate respective lamp type. <p>(Note – it may not be possible for all of the zone's envelopes, including glazing, to be equally split in approved software versions using a graphical interface. If this is the case the zone, its envelopes and glazing should be divided as equally as possible and the limitation recorded on site notes).</p>	
7.04	Display Lighting	<p>Where zones incorporate an activity whereby software SBEM automatically assumes the presence of display lighting but none is actually present, the display lighting efficiency for SBEM shall be entered such that it is the same as that of the general lighting present in that zone.</p> <p>Where possible this the display lighting efficiency should be calculated but as this requires detailed measurements of the lm and cW this is not usually practical in existing buildings. The following 'default' values should therefore be used:</p> <ol style="list-style-type: none"> 1. For all general lamp types except Tungsten or Tungsten Halogen; you must enter that the display lighting uses efficient lamps and enter 50lm/cW in the relevant Lumens per circuit wattage box, unless a specific lm/cW value from a lighting design exists is known. 2. For Tungsten or Tungsten Halogen lamps; you do not enter that the display lighting uses efficient lamps and you do not have to enter a value in the Lumens per circuit wattage box. 3. Where a zone contains a mixture of lamp types providing display lighting and some, but not all, are efficient lamps; you must enter that display lighting uses energy efficient lamps and enter a weighted average of the lm/cW based upon the number of lamps in the relevant Lumens per circuit wattage box. The weighted average is calculated using 50 lm/cW for efficient lamps and 15 lm/cW for Tungsten or Tungsten Halogen lamps. 	<p>17 January 2011</p> <p>Amended 1 July 2018</p> <p>Amended 1 February 2023</p>
7.05	Missing Lamp Selection	Where a lamp type is to be selected for a zone but no lamp is currently fitted the assessor should select the least efficient lamp type that can be housed in the installed light fitting. If no light fittings are observed or the acceptable lamp type(s) cannot be ascertained the default selection of 'tungsten' lamps must be made.	1 February 2012
7.06	2D Lamps	Where lamps are specifically identified via technical information and/or visual inspection as 'T5' lamps in a 2D configuration, and appropriate evidence is provided for this by the energy assessor they should be entered into SBEM as T5 lamps. In all other circumstances '2D' lamp fittings shall be entered into SBEM as compact fluorescent lamps, i.e. 'CFL'.	1 September 2014

Non Domestic EPC Conventions for England & Wales Issue 8

7.07	Modern LED Lighting	LED lighting technology has improved over recent years and where a lighting design has been carried out the information should be used to correctly reflect this. In the absence of a lighting design, assessors should use "Lighting parameters not available or unknown" and select "LED" for LED bulbs in bayonet / ES / SES fittings and "T5" for all other types of LED lamps.	1 May 2017 Removed for use in SBEM v5.4.a onwards from Issue 7 1 July 2018
8. EPBD Audit Trail			
9. Recommendations			
10. Appendices			
10.01	Commercial EPC Conventions	Glossary of Terms – Issue 1 Updated Glossary of Terms – Issue 2 Updated Glossary of Terms – Issue 4 Updated Glossary of Terms – Issue 5	1 June 2010 17 January 2011 30 November 2012 1 September 2014

Glossary of Terms

Air Permeability

Air permeability is expressed as volume flow per hour ($\text{m}^3 \text{h}$) of air supplied to the space per square metre (m^2) of envelope area for an internal to external pressure difference of 50 Pa i.e. $25 \text{ m}^3 \text{ hr}^{-1} \text{ m}^{-2}$ at 50Pa.

Atrium

In this context, a non-continuously occupied interior space within a building, often several stories high, bounded on at least one side by occupied spaces set to the conditions determined from the activity database. There may or may not be building elements (such as glazing) surrounding the atrium (although there may need to be something for smoke control in case of fire). The atrium itself is not maintained to the conditions set by the activity database for adjoining spaces. The technical purpose of the atrium can be one or more of the following:-

- Providing a buffer between the thermal conditions in the adjoining spaces and the exterior, to reduce the direct impact of the exterior on those zones. In this case it should not be maintained to conditions as though it is occupied. (If it is conditioned and the features below do not apply, in this context it is not considered to be an atrium.)
- Providing a means for daylight to reach the middle of deep plan spaces that would otherwise not receive it
- Encouraging stack effect or other passive ventilation to draw extract air from the adjoining spaces.

Automatic Blind Control

In this context internal or inter-pane (but not exterior) blinds that are motorised so that the position can be modified to control solar heat gain and/or glare, controlled by automatic sensors. The control regime must also open the blinds as the heat gain and or daylight levels decrease, so that the use of these natural resources can be optimised for each zone. Note that exterior shading devices can be modelled using iSBEM in the definition of each window; however SBEM currently does not model the re-radiation effects of blinds where solar gain has entered the space before it is modulated by the shading device.

Demand Controlled Ventilation

Is defined as supply and/or extract ventilation that is modulated to match the needs of the actual occupation level of each zone, rather than operating at a constant level defined by the activity database. Thus the energy required to adjust the condition of the supply air and that required to move the air can be reduced. The rate of ventilation would typically be controlled by presence detectors, CO_2 sensors or another device that senses the varying requirement.

Fixed Building Services

Are those which are directly attached or connected to the building and cannot be removed/disconnected without the use of tools. A portable electric heater with a plug allowing it to be removed from the building without the use of tools is not considered a fixed building service.

Light Pipes

A light pipe is a tube/pipe, consisting of internal reflective surfaces, which channels daylight to an internal area.

Lightwell

A lightwell is a space surrounded by the walls of a building but that has no roof or glazing above it. It is therefore similar to a courtyard in appearance. The walls that surround the lightwell are exposed to external air.

Mixed Use building

A building that incorporates both commercial areas and residential spaces.

Night Ventilation Strategy

Non Domestic EPC Conventions for England & Wales Issue 8

Can be defined as the presence of suitable systems, controls and operating strategy such that overnight ventilation (passive and/or mechanical) is used to cool down the exposed building mass and thereby offset daytime cooling demands. If no such operation and subsequent offset is possible through the *automatic* operation of systems and controls then night ventilation strategy is deemed to be not present as part of the building energy asset rating.

Self-contained dwelling

A unit designed to accommodate a single household. This would imply it has its own kitchen and bathroom.

Significant Alteration

Alterations that are covered by the Building Regulations.

Ventilation with Enhanced Thermal Coupling to Structure

This is a further development of the *Night Ventilation strategy* such that significant components of the building structure in addition to its ordinary surfaces are exposed to night ventilation, in order to enhance the building's capability of offsetting daytime cooling demands. An example of this procedure is the *TermoDeck* system where night ventilation is passed through ducts in the solid floors of the building, thereby increasing the 'coolth' contained in the thermal capacity of the building structure available to offset subsequent summertime daytime cooling loads.

Variable Speed Drive systems

HVAC system designs are increasingly incorporating variable speed drives (VSDs) to provide control, and reduce the energy consumption of, the motors on fans and pumps.

The term Variable-Speed Drive describes the equipment used to control the speed of pumps, fans and compressors. Variable speed drives may be purely mechanical, electromechanical, hydraulic, or electronic. It is generally accepted that variable speed pumping systems offer significant benefits compared to constant flow systems.

For alternating current (AC) electric motors this is achieved by controlling the frequency and/or voltage of the electrical power supplied to the motor. As the motor reduces the operating speed of the fan, pump or compressor the power required to operate the system is greatly reduced.

Non Domestic EPC Conventions for England & Wales Issue 8

10.02	Commercial EPC Delivery - Updated Assessment Level Decision Flow Chart Note: whilst level 3/4/5 categorisation is not prescribed elsewhere in Scottish EPC documentation, Approved Organisations are encouraged to apply this as a means of defining assessor competence and use of an appropriate assessment tool.	1 June 2010 1 February 2012 1 September 2014	17 January 2011 30 November 2012 Amended 1 May 2017
-------	---	--	--

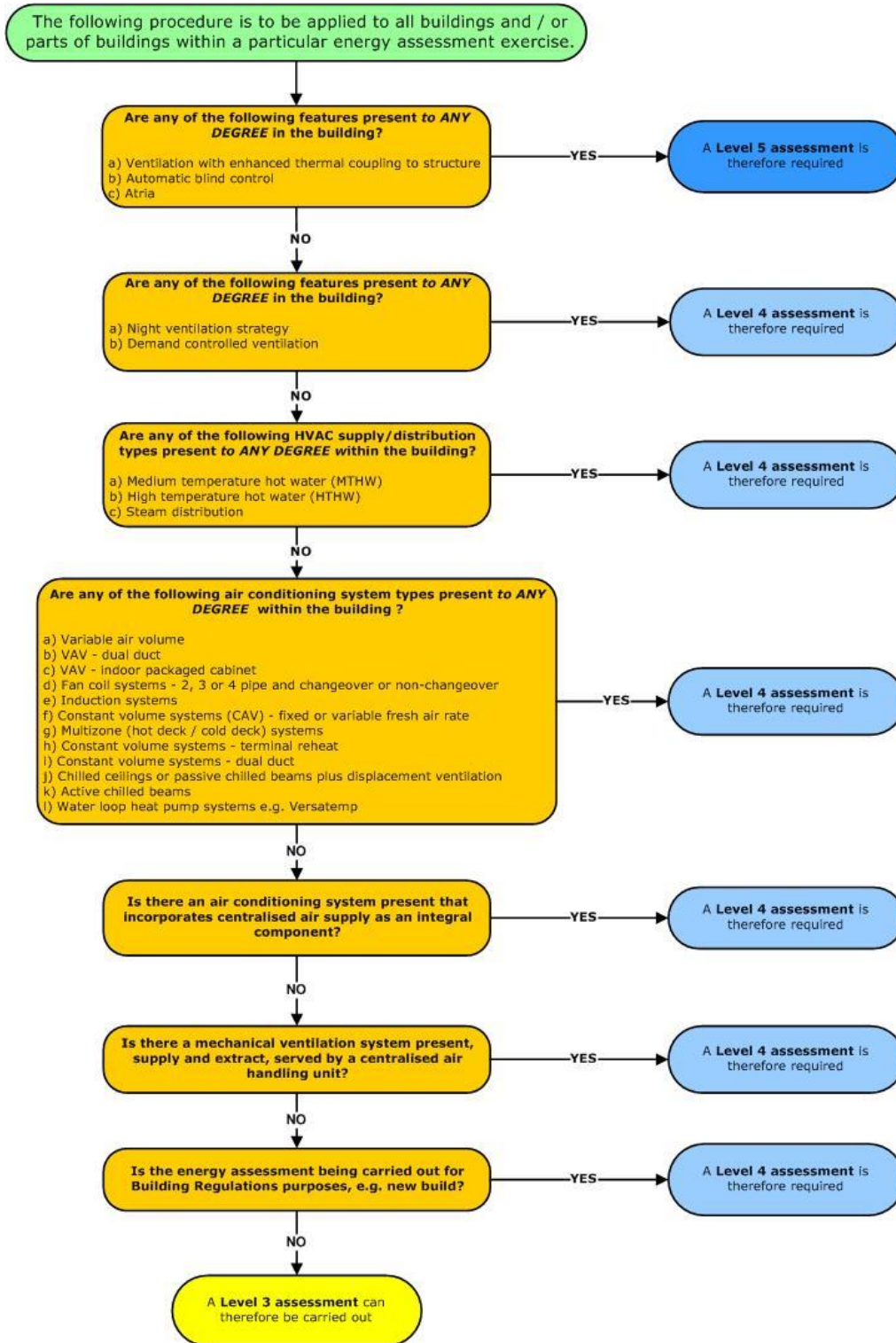

Non Domestic EPC Conventions for England & Wales Issue 8

Assessment Level Decision Flow Chart: Accompanying Notes

Night Ventilation Strategy

Can be defined as the presence of suitable systems, controls and operating strategy such that overnight ventilation (passive and/or mechanical) is used to cool down the exposed building mass and thereby offset daytime cooling demands. If no such operation and subsequent offset is possible through the *automatic* operation of systems and controls then night ventilation strategy is deemed to be not present as part of the building energy asset rating.

Ventilation with Enhanced Thermal Coupling to Structure

This is a further development of the *Night Ventilation strategy* such that significant components of the building structure in addition to its ordinary surfaces are exposed to night ventilation, in order to enhance the building's capability of offsetting daytime cooling demands. An example of this procedure is the *TermoDeck* system where night ventilation is passed through ducts in the solid floors of the building, thereby increasing the 'coolth' contained in the thermal capacity of the building structure available to offset subsequent summertime daytime cooling loads.

Demand Controlled Ventilation

Is defined as supply and/or extract ventilation that is modulated to match the needs of the actual occupation level of each zone, rather than operating at a constant level defined by the activity database. Thus the energy required to adjust the condition of the supply air and that required to move the air can be reduced. The rate of ventilation would typically be controlled by presence detectors, CO₂ sensors or another device that senses the varying requirement.

Automatic Blind Control

In this context internal or inter-pane (but not exterior) blinds that are motorised so that the position can be modified to control solar heat gain and/or glare, controlled by automatic sensors. The control regime must also open the blinds as the heat gain and or daylight levels decrease, so that the use of these natural resources can be optimised for each zone. Note that exterior shading devices can be modelled using iSBEM in the definition of each window; however SBEM currently does not model the re-radiation effects of blinds where solar gain has entered the space before it is modulated by the shading device.

Atrium

In this context, a non-continuously occupied interior space within a building, often several stories high, bounded on at least one side by occupied spaces set to the conditions determined from the activity database. There may or may not be building elements (such as glazing) surrounding the atrium (although there may need to be something for smoke control in case of fire). The atrium itself is not maintained to the conditions set by the activity database for adjoining spaces. The technical purpose of the atrium can be one or more of the following :-

- providing a buffer between the thermal conditions in the adjoining spaces and the exterior, to reduce the direct impact of the exterior on those zones. In this case it should not be maintained to conditions as though it is occupied. (If it is conditioned and the features below do not apply, in this context it is not considered to be an atrium.)
- providing a means for daylight to reach the middle of deep plan spaces that would otherwise not receive it
- encouraging stack effect or other passive ventilation to draw extract air from the adjoining spaces.

Dimensions Convention

Horizontal dimensions

Consider

- Plan view of two buildings in a terrace
 - Separated by a party wall
 - Building 1 has two zones
- Wall types
 - “Perimeter” surrounds each building (external and party walls)
 - “Internal” refers to walls within each building (partitions)

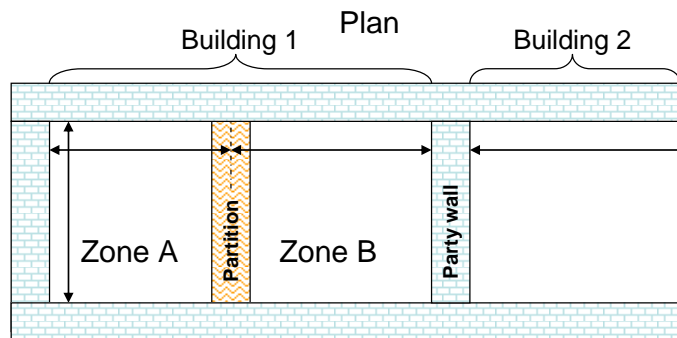

Generally follow RICS definition of Gross Internal Area

Need to measure

- Inside perimeter walls
- Mid point of internal walls
- Party walls are perimeter, so measure to surface, not mid point

Openings

- Inside structural opening ($w \times h$)
- *Not just glass area*
- Percentage glazing is as viewed from inside
 - i.e. percentage of wall area to full zone height (defined below)
- 100% Glazing
 - Enter a wall of total area
 - Enter glazing with same area (or as 100%)

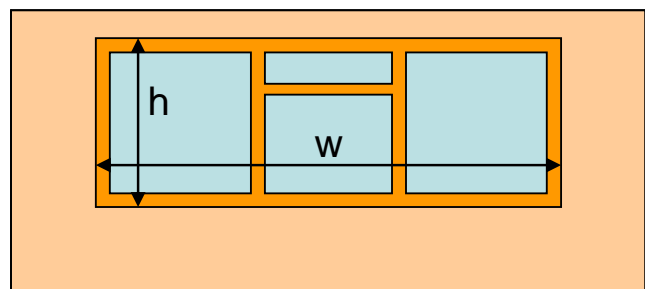

The following convention section is completely restructured for Issue 8.0. For comparison purposes only, the previous version is included in appendix A.

General principles

- For ground and intermediate floors
 - Zone height is top of floor to top of floor
 - Wall areas are calculated from top of floor to top of floor (*which will include the area of walls above dropped ceilings*)
- For top floors
 - Zone height is top of floor to soffit/underside of roof slab unless there is a lower ceiling of a type which is an effective thermal boundary that limits the extent of the conditioned space (*see below*)
 - Wall areas are calculated from top of floor to underside of the effective thermal boundary (*the total area exposed to the inside temperature*)
- For the roof
 - The U value is from under ceiling to outside roof including any insulation located within the construction(s)
 - The envelope area is the total area exposed to the inside temperature (*which will be greater than the zone area unless the ceiling is flat*)

Non Domestic EPC Conventions for England & Wales Issue 8

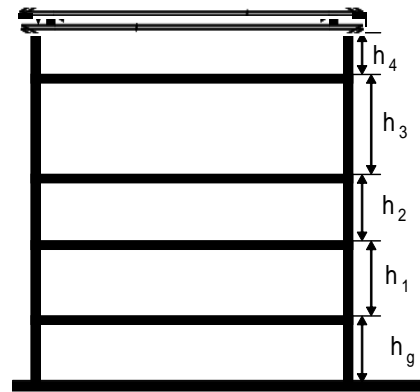
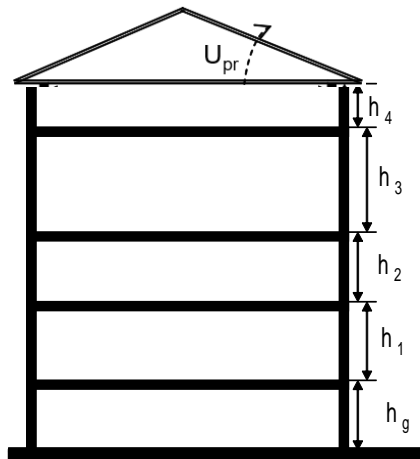

Specific examples

For top floors with a flat ceiling at eaves level

- Zone height is top of floor to underside of soffit/eaves level (h_4)
- Area of walls are those below soffit/eaves level i.e. length L_4 x h_4

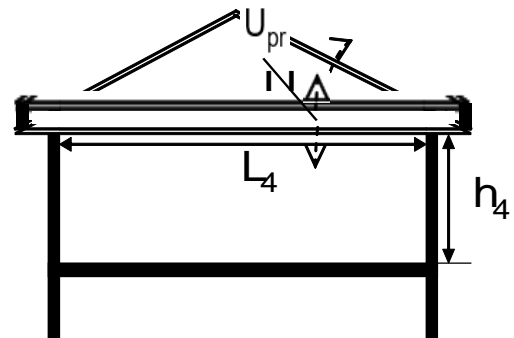
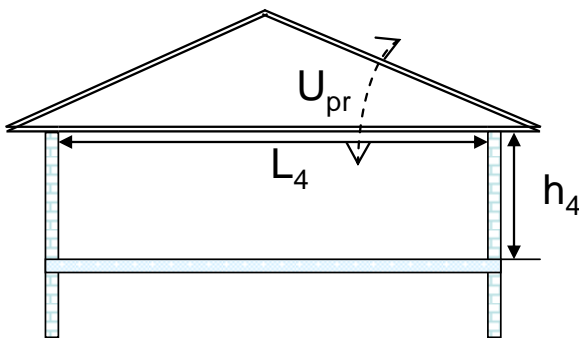

For top floors with dropped **permeable ceiling without insulation** at ceiling level

- Zone height (h_4) is top of floor to underside of soffit/eaves level (not ceiling)
- Side and end wall areas are calculated to soffit/eaves level i.e. dropped ceiling is treated as though it is at soffit/eaves level

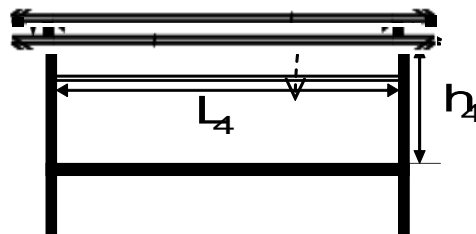
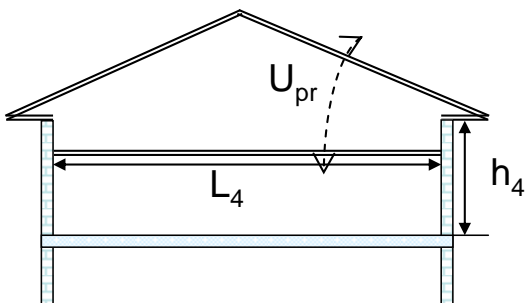

For top floors with dropped **non-permeable ceiling** with or without insulation at ceiling level
or **permeable ceiling with an insulation layer across the entire ceiling**

- Zone height (h_3) is top of floor to underside of ceiling
- Side and end wall areas are calculated to underside of ceiling i.e. L x h_3

Non Domestic EPC Conventions for England & Wales Issue 8

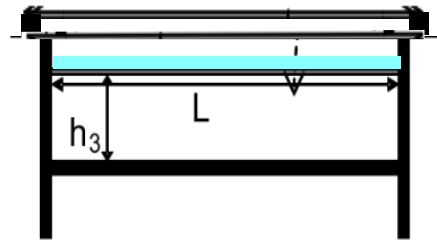
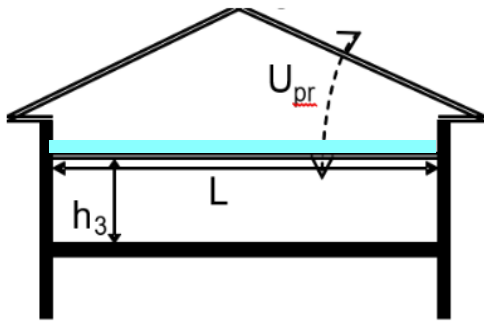

- For rooms with pitched ceiling (e.g. where ceiling is fixed in line of pitched roof)
 - Zone height (h_4) is top of floor to underside of soffit/eaves level (*not average room height*)
 - Roof heat loss area is as seen from underside of ceiling, i.e. $L_r \times d$ (zone depth)
 - U value is from under ceiling to outside roof (U_r)
 - End wall area is whole gable up to roof apex (as this is all exposed to inside temperature)

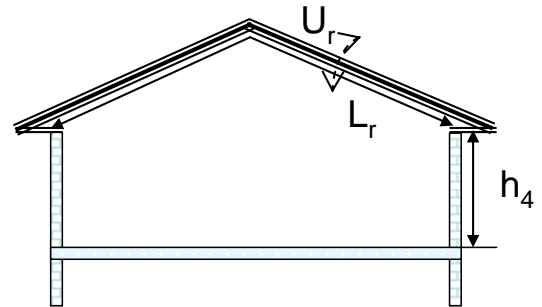

- If there is a horizontal ceiling half way up the pitched roof, split the area into
 - The part with a void (L_{r1}), using the U-value including the void (U_{r1})
 - The part where there is no void (L_{r2} , L_{r3}), using the U-value without a void (U_{r2})
 - Zone height is still to underside of soffit/eaves level

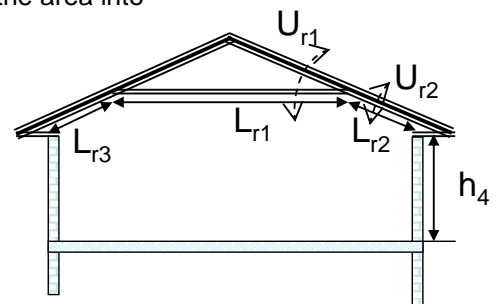

the general rule is always to **input the area exposed to the inside temperature, and the U-value between this surface and outside.**

For the purposes of this convention the following ceilings, as seen from underneath, are to be considered non-permeable or permeable to the movement of air:

Non-Permeable Ceilings

- Plasterboard Ceilings
- Lath & Plaster Ceilings
- Seamless PVC ceiling
- OSB board, Chipboard or plywood ceiling
- in situ concrete ceiling
- beam & block with concrete screed ceiling
- Seamless aluminium or metal ceiling

Permeable ceilings

- Suspended ceiling tiles in a grid
- Louvred timber, metal or plastic slatted ceiling
- Perforated aluminium or metal ceiling

Non Domestic EPC Conventions for England & Wales Issue 8

Dimensions Convention (continued)

- Intermediate floors with suspended ceilings and raised floors

- Zone height is top of floor slab to top of next floor slab e.g. h_1
- So, ignore the suspended ceilings and raised floors for the purposes of
 - zone height
 - surrounding wall areas
- But include their impact on Kappa values of the slabs above and below so that thermal mass effects are calculated correctly

- With suspended timber ground floor and ventilated void below

- Zone height is top of suspended floor surface to top of first floor surface (h_{sf})
- Where the floor U value is calculated it should take account of the ventilated void (U_{sf})

When there are walls of different heights to consider:

- For sloping floors and ceilings (e.g. auditoria)
 - If the activity above and under the floor is the same, or the void is inaccessible, choose normal zone height, otherwise
 - zone height = weighted average external wall height h_{a1} , h_{a2} , h_{a3} , etc (from where floor adjoins each wall to top of floor above)
 - Zone area A_a is projected area/plan area as per RICS GIA standard
 - Make sure in addition that all external (and internal) wall and slab areas are input so that all heat loss/gain and thermal mass is calculated
 - **Note that zoning for daylight areas must be carried out manually in these circumstances (do not use automatic daylight zoning)**
- For cubical rooms under the sloping floor
 - Zone height = top of slab to top of slab (h_s)

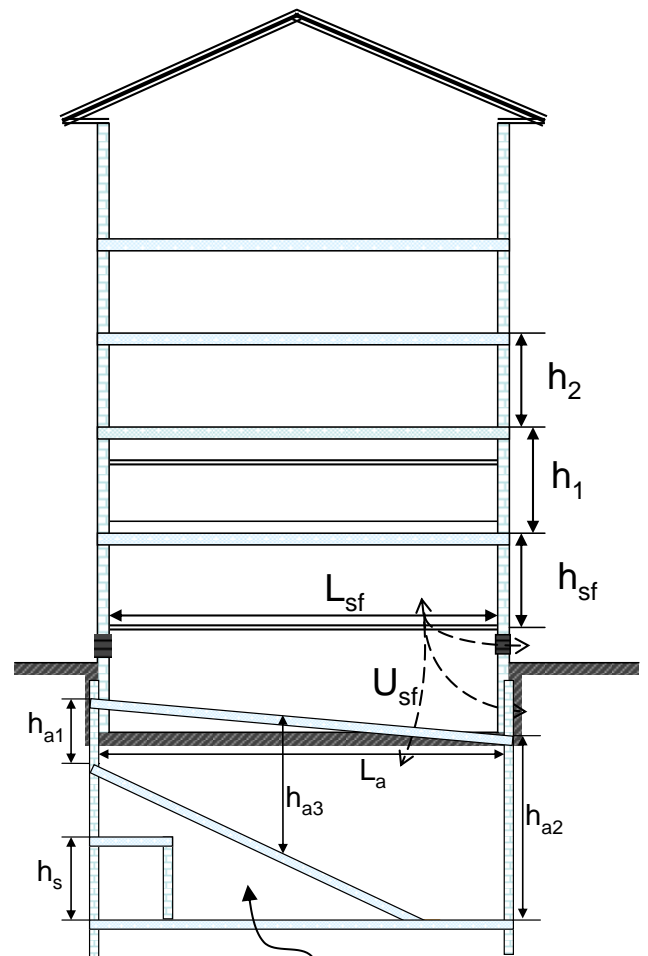

Don't forget this void is another zone if it has a different activity! Its zone height = area weighted average vertical wall height. If it has the same activity or is inaccessible, then merge with auditorium and enter zone area as though the floor is flat ($L_a \times d$). However, the sloping floor area must be input so that thermal mass is calculated.)

Non Domestic EPC Conventions for England & Wales Issue 8

Dimensions Convention (continued)

- For rooms with mono-pitched ceiling
 - Zone height is top of floor to weighted average height of all external walls - h_{4av}
 - Area of roof (A_r) is as seen from underside i.e. L_r x zone depth
 - U value from under ceiling to outside roof is U_r
 - Use total area of external gable wall
 - **Note that zoning for daylight areas must be carried out manually in these circumstances**

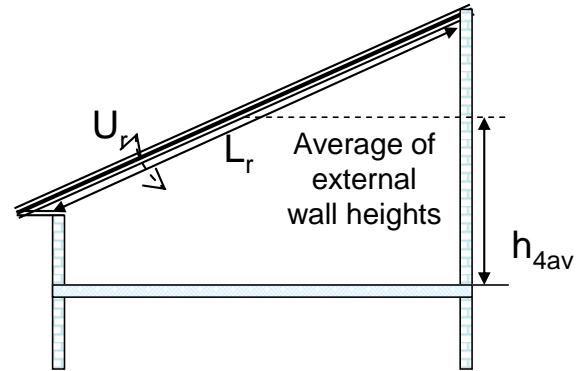

- If there is a horizontal ceiling under the mono-pitched roof
 - Level with or below eaves: zone height at eaves
 - Above eaves: zone height = average exposed wall height
 - Roof area would have to be divided into areas with different U-values with and without void
- **Curved roof** – all buildings with curved roof sections shall be approximated as in the diagram:
 - Circular (not elliptical or other shapes)
 - Semi-circular so that width = 2 x height

- Walls are 70-90° from horizontal, roofs are <70°
- So zone height h_{cw} = dividing point between wall and roof, where slope = 70° at "eaves"
- If a floor (e.g. as shown dotted) meets roof at <70°, there is no wall, so zone height h_{cr} = average height of space
- If the dotted line represents the ceiling with an unoccupied void above, remember to input
 - the area of roof where the slope < 70° between this ceiling and the "eaves", with its U value (U_{rc}), and
 - the flat ceiling with U value (U_{clg}) including the void above the ceiling
- Treat dormer windows the same as for a room in a pitched roof (see below)

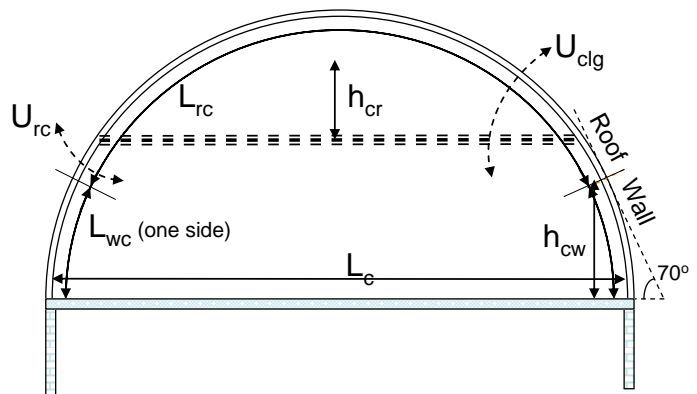

For consistency, the convention is to assume all such roofs are semi-circular. If floor width = L_c and building depth is d

- Zone height $h_{cw} = 0.171 \times L_c$
- Wall height $L_{wc} = 0.175 \times L_c$
- Area curved walls = $L_{wc} \times d \times 2$ (both sides)
- Curved roof width $L_{rc} = 1.222 \times L_c$
- Area curved roof = $L_{rc} \times d$

Non Domestic EPC Conventions for England & Wales Issue 8

Dimensions Convention (continued)

- For room in roof (or mansard roof):
 - Areas and U values should correspond
 - U values for walls should include any voids – U_{w1} , U_{w2}
 - Zone height (h_{w1}) = height of vertical part of walls adjacent to exterior
 - If this varies, calculate area weighted average height of external walls

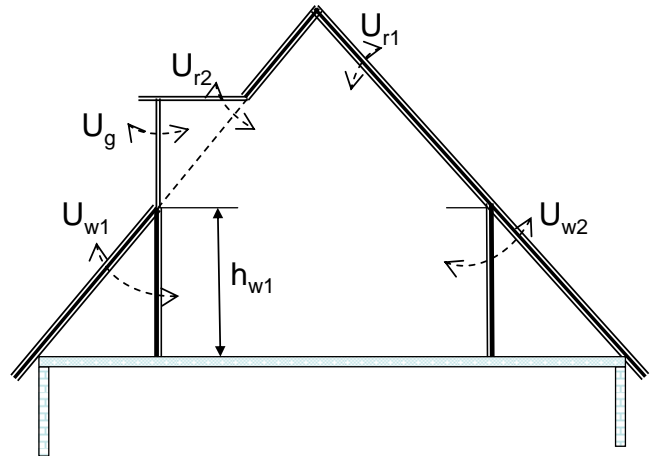

- Where there are dormer windows (i.e. window bays that project through the roof)
 - Do not adjust zone height for the dormer windows
 - Zone manually for daylight areas (if the glazing > 20% of vertical wall area)
 - Enter the glazing details and areas as normal
 - **Note that zoning for daylight areas must be carried out manually in these circumstances**

Non Domestic EPC Conventions for England & Wales Issue 8

Non Domestic Situations

10.04	Local Mechanical Exhaust Rates	1 st June 2010 17 th January 2011 Amended 1 July 2018 Amended 1 November 2018
-------	--------------------------------	--

Activity	Sub Type (if applicable)	Air changes/hour
Auditoria		10
Bathroom		10
Bedroom	Bedroom only	4
	Bedroom with ensuite (bedroom unit)	6
Car park		6
Cell (police / prison)		10
Changing facility with showers / communal shower room		20
Check in areas		6
Circulation area		5
Computer room	Computer lab / suite	10
	Data centre / server room	6
Display and public areas in library / museum / gallery		6
Display window		As adjacent zone activity
Dry sports hall		6
Eating/drinking area	Hotel bar	10
	Canteen	12
	Cafe, coffee bar, restaurant, public bar	15
Fitness suite / gym		12
Exercise / dance studio		20
Hall / lecture theatre / assembly area	Exc. libraries	10
	Libraries	4
Ice rink		6
Industrial process area	Factory (general)	10
	Electroplating	12
	Welding shops (general extract), foundries, dye works	30
	Glass houses	60
Kitchen	Commercial food prep	40
	Residents kitchen	15
Laboratory		15
Laundry		15
Lounges		10
Office / consulting area		10
Performance area (stage)		6
Plant room	Light plant room	30
	Heavy plant room	6
Reception		10
Residents common rooms		6
Sales area (all types)		10
Store room		6
Swimming pool		10
Teaching areas (classrooms)		6
Toilet / locker room		10
Waiting room		10
Warehouse		6

Non Domestic EPC Conventions for England & Wales Issue 8

Workshop (small scale)	Darkrooms	8
	Workshop garages	10
	Recording studio	12
	Other (not one of the above)	6

Domestic situations

Activity	Sub Type	Air changes/hour
Domestic bathroom		10
Domestic bedroom		4
Domestic circulation		6
Domestic dining room		6
Domestic kitchen		15
Domestic lounge		6
Domestic toilet		10

Room or Building	Air Changes per Hour
Assembly Rooms	10
Bakeries	30
Banks/Building Societies	6
Bathroom (non domestic) without Shower	8
Bathroom (non domestic) with Shower	20
Bathroom (domestic)	10
Bedrooms	4
Boiler Rooms	30
Cafés and Coffee Bars	15
Canteens	12
Cellars	10
Cinemas and Theatres	10
Club / Games Rooms	10
Compressor Rooms	20
Conference Rooms	10
Dairies	10
Night Club / Disco	20
Dye Works	30
Electroplating Shops	12
Engine Rooms	30
Entrance Halls, Corridors	5
Factories and Workshops	10
Fitness Centres	12
Foundries	30
Garages (workshop)	10
Glass houses	60
Hairdressing Salons	15
Hotel Bars	10
Kitchens – Non Domestic	40
Kitchens – Domestic	15
Laboratories	15
Launderettes / Laundries	15
Lecture Theatres	10
Libraries	4
Living Rooms	6
Meeting Room	10
Offices	6
Photo and X-ray Darkrooms	8
Public House Bars	15
Recording Studios	12
Restaurants	15
Schoolrooms	10 l/s/Person
Shops and Supermarkets	10
Sports Hall / Squash Courts / Gymnasiums	6

Non Domestic EPC Conventions for England & Wales Issue 8

Stores and Warehouses	6
Swimming Pools	10
Tea Making	10
Toilets	10
Utility Rooms	20
Welding Shops (General Extract)	30

10.05	SBEM Weather Locations	1 st February 2012
-------	------------------------	-------------------------------



CL2_1 SBEM
Weather Locations Lc



CL2_1 SBEM
Weather Locations Lc



CEPC CL2.1 SBEM
Weather Locations+F

Non Domestic EPC Conventions for England & Wales Issue 8

10.06	Roofs with Multiple Components	21 January 2013
-------	--------------------------------	-----------------

Roofs with Multiple Components

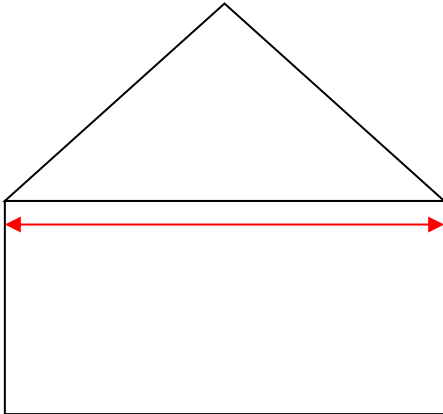

Horizontal internal ceiling (Example 1)

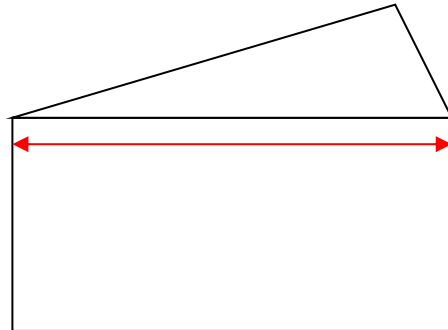

Horizontal internal ceiling (Example 2)

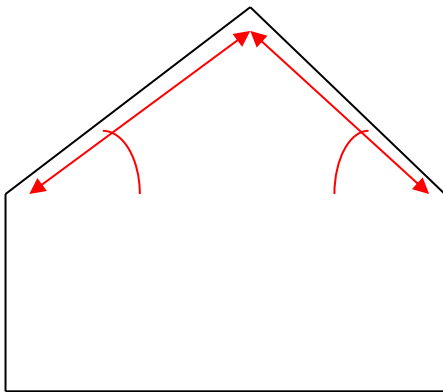

No horizontal internal ceiling

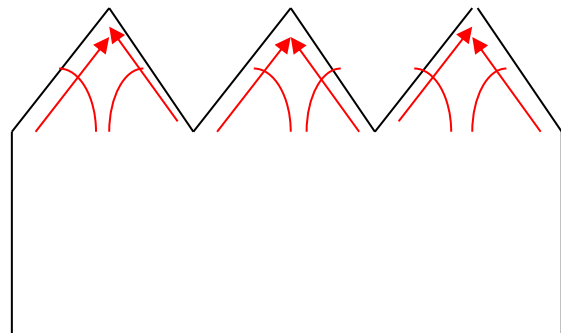

Roof structure with number of pitched components

10.07	<p>Zones Without Fixed Conditioning Equipment</p> <p>To be applied in circumstances where the zone(s) or building being assessed has some or all of its building services missing and is subject to the requirements of a first fit out – e.g. Shell and Core. In this circumstance, the assessor must determine which type of building service would likely be installed (the assessor should record justification of this in their Site Notes) and assign the minimum efficiency allowed</p>	<p>1 September 2014</p> <p>Amended 1 May 2017</p> <p>Amended 1 February 2023</p>
-------	--	--

Non Domestic EPC Conventions for England & Wales Issue 8

	under Part L. This is done by referring to Approved Document L2 (2021) , and assigning the minimum energy efficiency standard that is stated for that particular system/building service.	
--	---	--

Zones Without Fixed Conditioning Equipment

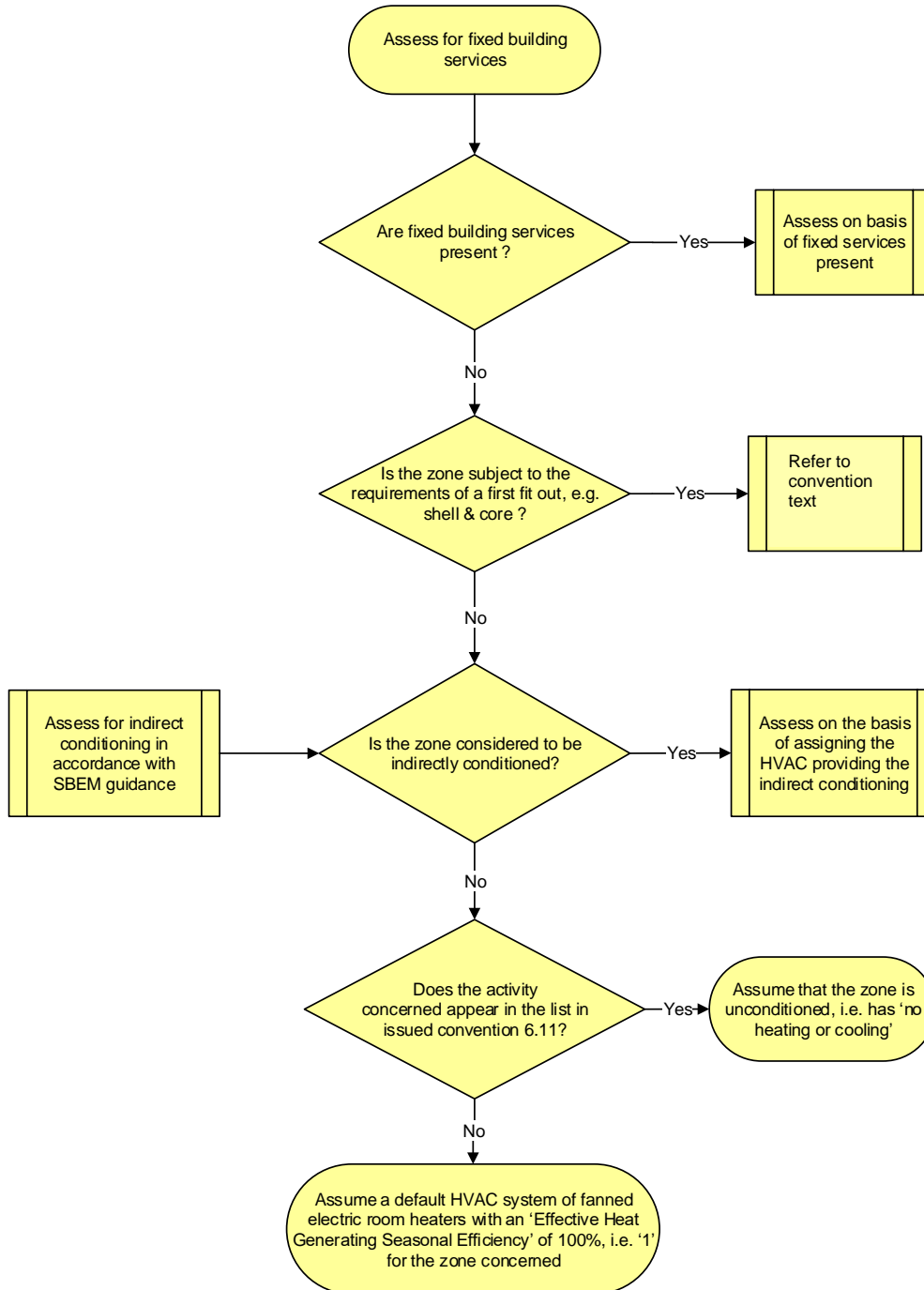

10.08	Sales vs Eating & Drinking Activity Selection	1 May 2017
-------	---	------------

Non Domestic EPC Conventions for England & Wales Issue 8

The possible options for 'eating and drinking' activity types are as follows:-

Building Type	Activity	Description
A1/A2 Retail and Financial/Professional Services	Eating/drinking area	An area specifically designed for eating and drinking
A3/A4/A5 Restaurants and Cafes/Drinking Establishments and hot food takeaways	Eating/drinking area	Areas where food or drink are consumed. This could include open corridors or stairs providing access to the main eating/drinking spaces. For a hot food takeaway, the main area should incorporate tables and chairs, otherwise it will be entered as a sales area
B1 Offices and Workshop Businesses	Eating/drinking area	Areas where food or drink are consumed by staff and visitors, e.g. canteen or office restaurant sitting areas
B2 to B7 General Industrial and Special Industrial Groups	Eating/drinking area	Areas where food or drink are consumed by staff and visitors, e.g. canteen or office restaurant sitting areas
B8 Storage or Distribution	Eating/drinking area	Areas where food or drink are consumed by staff and visitors, e.g. canteen or office restaurant sitting areas
C1 Hotels	Eating/drinking area	Areas where food or drink is consumed, e.g. restaurant
C2 Residential Institutions – Hospitals and Care Homes	Eating/drinking area	An area specifically designed for eating and drinking
C2 Residential Institutions – Residential Schools	Eating/drinking area	Seated areas where food or drink are consumed by residents & staff
C2 Residential Institutions – Universities and Colleges	Eating/drinking area	Seated areas where food or drink are consumed, e.g. canteen
C2A Secure Residential Institutions	Eating/drinking area	Seated areas where food or drink are consumed, e.g. canteen
D1 Non-residential Institutions – Community/Day Centre	Eating/drinking area	Seated areas where food or drink are consumed by residents & staff
D1 Non-residential Institutions – Crown and County Courts	Eating/drinking area	An area specifically designed for eating and drinking
D1 Non-residential Institutions – Education	Eating/drinking area	Seated areas where food or drink are consumed
D1 Non-residential Institutions – Libraries Museums and Galleries	Eating/drinking area	Seated areas where food or drink are consumed
D2 General Assembly and Leisure plus Night Clubs and Theatres	Eating/drinking area	An area specifically designed for eating and drinking
Others – Emergency Services	Eating/drinking area	An area specifically designed for eating and drinking
Others – Passenger terminals	Eating/drinking area	Areas where food or drink are consumed by members of staff e.g. staff canteen

Non Domestic EPC Conventions for England & Wales Issue 8

Appendix A: previous (v7.1) iteration of convention 10.03

The convention text below is no longer applicable as of [implementation date of issue 8] and is included for comparative purposes only.

10.03 Dimensions Convention

1st June 2010
17th January 2011

Dimensions Convention

Horizontal dimensions

Consider

- Plan view of two buildings in a terrace
 - Separated by a party wall
 - Building 1 has two zones
- Wall types
 - “Perimeter” surrounds each building (external and party walls)
 - “Internal” refers to walls within each building (partitions)

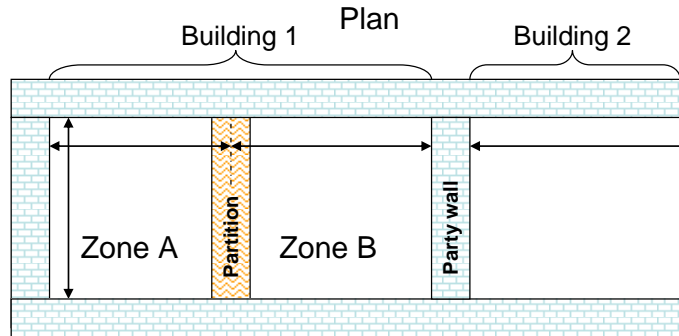

Generally follow RICS definition of Gross Internal Area

Need to measure

- Inside perimeter walls
- Mid point of internal walls
- Party walls are perimeter, so measure to surface, not mid point

Openings

- Inside structural opening ($w \times h$)
- *Not just glass area*
- Percentage glazing is as viewed from inside
 - i.e. percentage of wall area to full zone height (defined below)
- 100% Glazing
 - Enter a wall of total area
 - Enter glazing with same area (or as 100%)

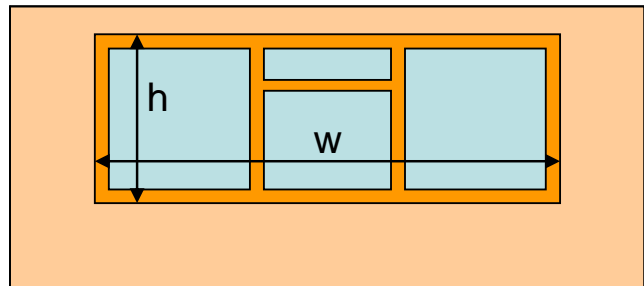

Zone height and element areas

Generally zone height is top of slab to top of slab for ground and intermediate floors, or soffit/eaves level at roof level

- For ground and intermediate floors
 - Zone height is top of floor to top of floor
- For top floors with flat roof
 - Zone height is top of floor to soffit/underside of roof slab

Dimensions Convention (continued)

- For top floors with pitched roof but flat ceiling
 - Zone height is top of floor to underside of soffit/eaves level

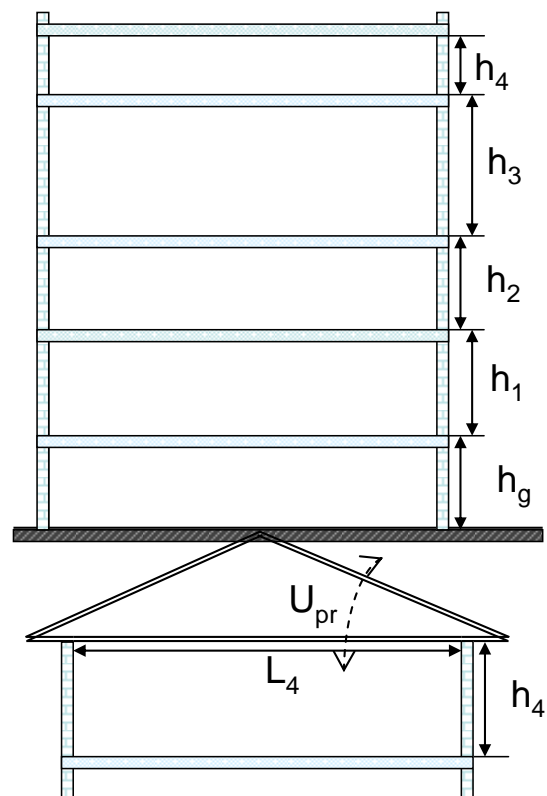

Non Domestic EPC Conventions for England & Wales Issue 8

- U value is from under ceiling to outside roof including insulation wherever it is
 - that is, consistent with the area being entered
 - Area of gable wall is that below soffit/eaves level i.e. length L_4 x h_4
- For top floors with pitched roof and dropped ceiling with or without insulation at ceiling level

- Zone height (h_4) is top of floor to underside of soffit/eaves level (not ceiling)
- U value is from under ceiling to outside roof
- Side and end wall areas are calculated to soffit/eaves level i.e. dropped ceiling is treated as though it is at soffit/eaves level

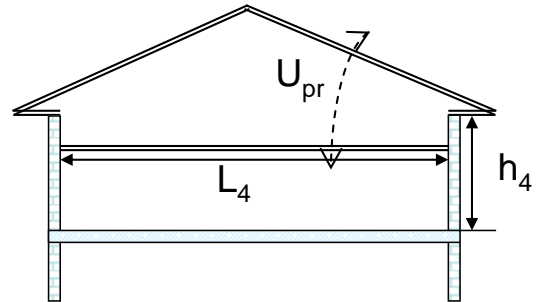

- For rooms with pitched ceiling (e.g. where ceiling is fixed in line of pitched roof)

- Zone height (h_4) is top of floor to underside of soffit/eaves level (*not average room height*)
- Roof heat loss area is as seen from underside of ceiling, i.e. L_r x d (zone depth)
- U value is from under ceiling to outside roof (U_r)
- End wall area is whole gable up to roof apex (as this is all exposed to inside temperature)

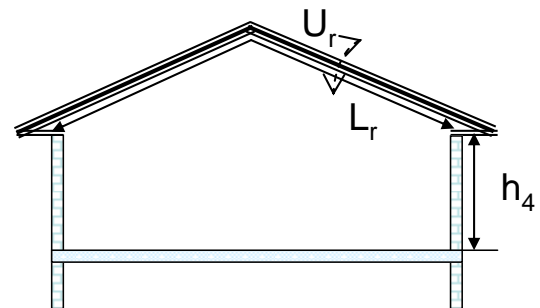

- If there is a horizontal ceiling half way up the pitched roof, split the area into

- The part with a void (L_{r1}), using the U-value including the void (U_{r1})
- The part where there is no void (L_{r2} , L_{r3}), using the U-value without a void (U_{r2})
- Zone height is still to underside of soffit/eaves level

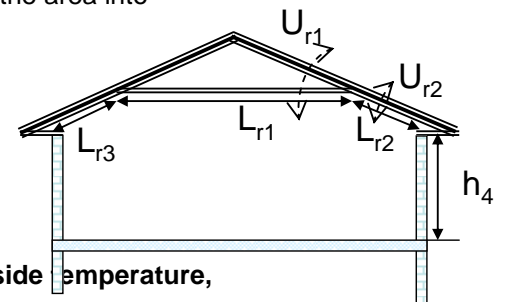

So the general rule is always to **input the area exposed to the inside temperature, and the U-value between this surface and outside.**

Non Domestic EPC Conventions for England & Wales Issue 8

Dimensions Convention (continued)

- Intermediate floors with suspended ceilings and raised floors

- Zone height is top of floor slab to top of next floor slab e.g. h_1
- So, ignore the suspended ceilings and raised floors for the purposes of
 - zone height
 - surrounding wall areas
- But include their impact on Kappa values of the slabs above and below so that thermal mass effects are calculated correctly

- With suspended timber ground floor and ventilated void below

- Zone height is top of suspended floor surface to top of first floor surface (h_{sf})
- Where the floor U value is calculated it should take account of the ventilated void (U_{sf})

When there are walls of different heights to consider:

- For sloping floors and ceilings (e.g. auditoria)
 - If the activity above and under the floor is the same, or the void is inaccessible, choose normal zone height, otherwise
 - zone height = weighted average external wall height h_{a1} , h_{a2} , h_{a3} , etc (from where floor adjoins each wall to top of floor above)
 - Zone area A_a is projected area/plan area as per RICS GIA standard
 - Make sure in addition that all external (and internal) wall and slab areas are input so that all heat loss/gain and thermal mass is calculated
 - **Note that zoning for daylight areas must be carried out manually in these circumstances (do not use automatic daylight zoning)**
- For cubical rooms under the sloping floor
 - Zone height = top of slab to top of slab (h_s)

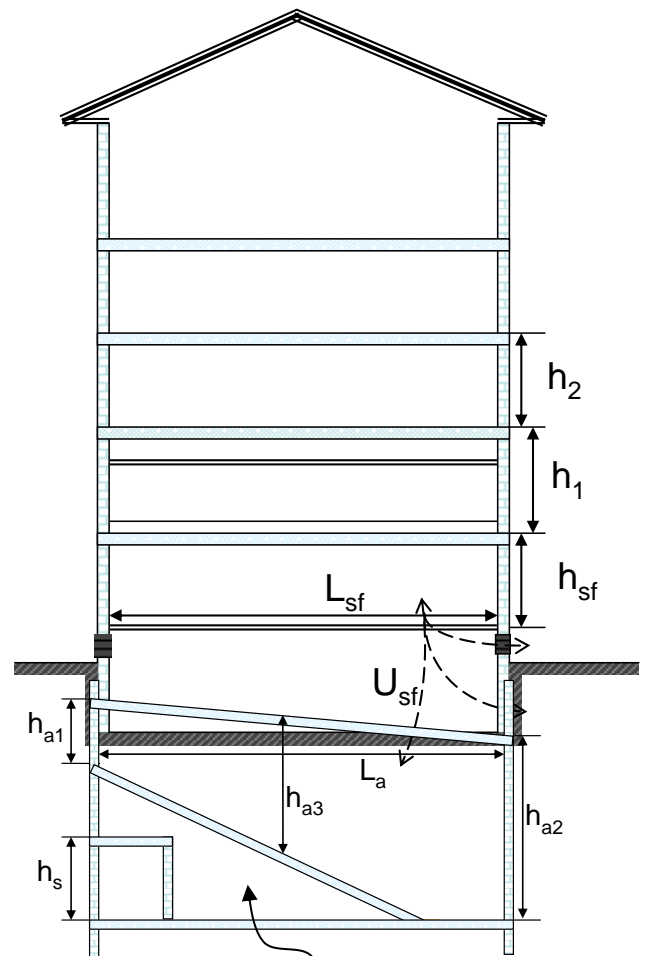

Don't forget this void is another zone if it has a different activity! Its zone height = area weighted average vertical wall height. If it has the same activity or is inaccessible, then merge with auditorium and enter zone area as though the floor is flat ($L_a \times d$). However, the sloping floor area must be input so that thermal mass is calculated.)

Non Domestic EPC Conventions for England & Wales Issue 8

Dimensions Convention (continued)

- For rooms with mono-pitched ceiling
 - Zone height is top of floor to weighted average height of all external walls - h_{4av}
 - Area of roof (A_r) is as seen from underside i.e. L_r x zone depth
 - U value from under ceiling to outside roof is U_r
 - Use total area of external gable wall
 - **Note that zoning for daylight areas must be carried out manually in these circumstances**

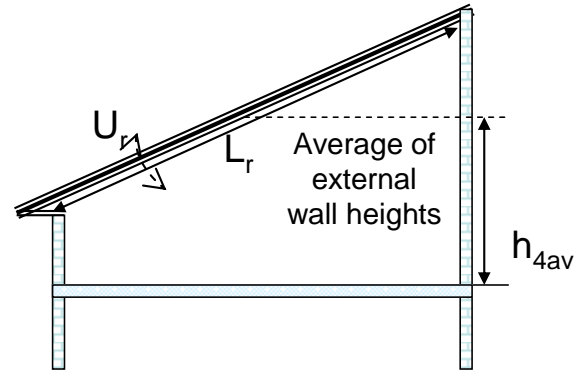

- If there is a horizontal ceiling under the mono-pitched roof
 - Level with or below eaves: zone height at eaves
 - Above eaves: zone height = average exposed wall height
 - Roof area would have to be divided into areas with different U-values with and without void
- **Curved roof** – all buildings with curved roof sections shall be approximated as in the diagram:
 - Circular (not elliptical or other shapes)
 - Semi-circular so that width = 2 x height

- Walls are 70-90° from horizontal, roofs are <70°
- So zone height h_{cw} = dividing point between wall and roof, where slope = 70° at "eaves"
- If a floor (e.g. as shown dotted) meets roof at <70°, there is no wall, so zone height h_{cr} = average height of space

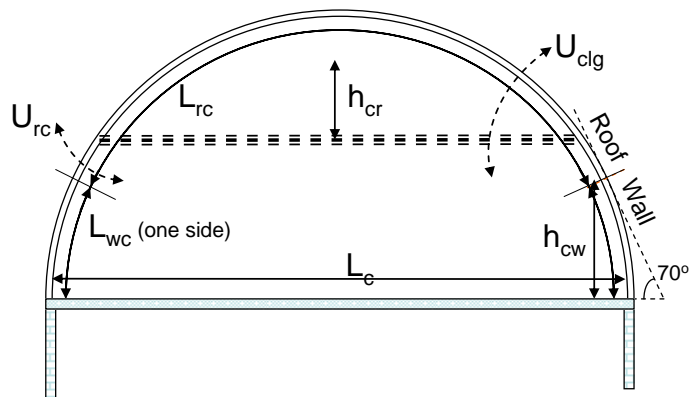

- If the dotted line represents the ceiling with an unoccupied void above, remember to input
 - the area of roof where the slope < 70° between this ceiling and the "eaves", with its U value (U_{rc}), and
 - the flat ceiling with U value (U_{clg}) including the void above the ceiling
- Treat dormer windows the same as for a room in a pitched roof (see below)

For consistency, the convention is to assume all such roofs are semi-circular. If floor width = L_c and building depth is d

- Zone height $h_{cw} = 0.171 \times L_c$
- Wall height $L_{wc} = 0.175 \times L_c$
- Area curved walls = $L_{wc} \times d \times 2$ (both sides)
- Curved roof width $L_{rc} = 1.222 \times L_c$
- Area curved roof = $L_{rc} \times d$

Non Domestic EPC Conventions for England & Wales Issue 8

Dimensions Convention (continued)

- For room in roof (or mansard roof):
 - Areas and U values should correspond
 - U values for walls should include any voids – U_{w1} , U_{w2}
 - Zone height (h_{w1}) = height of vertical part of walls adjacent to exterior
 - If this varies, calculate area weighted average height of external walls
- Where there are dormer windows (i.e. window bays that project through the roof)
 - Do not adjust zone height for the dormer windows
 - Zone manually for daylight areas (if the glazing > 20% of vertical wall area)
 - Enter the glazing details and areas as normal
 - **Note that zoning for daylight areas must be carried out manually in these circumstances**

